

# PRODUCT CATALOGUE

CIVIL



## MISSION STATEMENT

---

### VISION

To be the safest and most innovative Australian manufacturer relentless in the pursuit of employee and customer excellence.

### MISSION

To be a responsible employer and leading innovator of sustainably manufactured high quality products for mining, industrial and infrastructure markets. Accountable to our stakeholders by creating employee and customer excellence, and positive outcomes for all.



# Contacts

## Administration

---

### Head Office and Plant

#### Jason Matthews

Civil and Tunnelling

E-mail: [jmatthews@jenmar.com.au](mailto:jmatthews@jenmar.com.au)

Mobile: 0437 771 781

#### Desmond Baard

Sales Manager

E-mail: [dbaard@jenmar.com.au](mailto:dbaard@jenmar.com.au)

Mobile: 0499 149 788

#### Matthew Berry

Commercial Manager

E-mail: [mberry@jenmar.com.au](mailto:mberry@jenmar.com.au)

Mobile: 0408 269 658

#### Rajendra Singh

National Quality Manager

E-mail: [rsingh@jenmar.com.au](mailto:rsingh@jenmar.com.au)

Mobile: 0499 213 811

#### Blair Moses

National Safety & Environmental Manager

E-mail: [bmoses@jenmar.com.au](mailto:bmoses@jenmar.com.au)

Mobile: 0455 612 821



# Accreditations

JENNMAR Australia is certified as compliant with the following standards:



OHS  
ISO 45001



Quality  
ISO 9001



Environment  
ISO 14001



# Contents

Mission Statement.....	2	<b>PLATES</b>	
Contacts.....	4	Plastic Plates: 22 - 25mm Dowels.....	57
Accreditations.....	5	Kanga Plate to suit Temporary Rock Bolt.....	58
<b>DOUBLE CORROSION PROTECTION</b>		Kanga Plate to suit Threaded and Temporary	
<b>ROCK BOLTS &amp; CABLES</b>		Rock Bolts.....	59
SR Bolt.....	8-9	Volcano Plate to suit 25mm Threaded Bolts.....	60
Low Profile Double Corrosion Protection Rock Bolt....	10-11	Black Volcano Handle Bar Plate to Suit SR Bolt	
DCP Cable Bolt - 21.8mm.....	12-13	with Black Grout Bell.....	61
DCP Cable Bolt - 18mm.....	14-15	316 SS Volcano Plate to suit SR Bolt with	
Grout Lance To Suit M24 Sr Bolt.....	16	316 SS Grout Bell.....	62
Grout Nozzle To Suit M24 Low Profile Bolt.....	17	316 SS Volcano Handle Bar Plate to suit SR Bolt	
Grout Head To Suit 22mm Dcp Cable Bolt.....	18	with 316 SS Grout Bell.....	63
Grout Head To Suit 18mm Dcp Cable Bolt.....	18	316 SS Volcano Plate to suit Low Profile Bolt and the	
<b>TEMPORARY ROCK BOLTS</b>		18mm DCP Cable Bolt Both with 316 SS Grout Bell....	64
J-Tech® 20mm All Thread Bolt.....	20-21	316 SS Volcano Handle Bar Plate to suit Low Profile	
J-Tech® 25mm All Thread Bolt.....	22-23	Bolt and the 18mm DCP Cable Bolt Both with 316 SS	
Python Bolt.....	24	Grout Bell.....	65
Friction Lok Bolt.....	25-26	316 SS Volcano Handle Bar Plate to Suit 22mm	
M24 High Tensile Temporary Rock Bolt.....	27	DCP Cable Bolt with 316 SS Grout Bell.....	66
Expansion Shell M24 To Suit 45mm Hole RH.....	28	Roll Top Plate.....	67
Expansion Shell M24 To Suit 45mm Hole LH.....	28	<b>SPECIALITY GROUT AND CEMENT</b>	
Expansion Shell M24 To Suit 51mm Hole LH.....	28	Bottom-Up 100 MPa Grout.....	69
<b>THREADBAR SYSTEM</b>		Top-Down 80 MPa Grout.....	70
JMA500N Threadbar System.....	30-31	J-PLUG Grout.....	71
<b>SELF DRILLING HOLLOW BOLTS &amp; ACCESSORIES</b>		J-URR GROUT (Jennchem Underground	
Hollow Self Drilling Bolt.....	33-34	Roadway Repair).....	72
Drilling Bit Accessories.....	35-36	<b>RESIN CAPSULES</b>	
Accessories.....	37	'5 Star' Dual Speed (Water Based Catalyst)	
<b>CABLE BOLTS &amp; ACCESSORIES</b>		Resin Capsules.....	74
100T Goliath Cable Bolt.....	39	'5 Star' Single Speed (Water Based Catalyst)	
100T Bulbed Goliath Cable Bolt.....	40	Resin Capsules.....	75
70T 12 Wire Sumo Cable Bolt.....	41	Standard Dual Speed (Oil Based Catalyst)	
70T 10 Wire Hollow Cable Bolt.....	42	Resin Capsules.....	76
31mm 70T SUMO TEX Cable.....	43	Standard Single Speed (Oil Based Catalyst)	
Superstrand Cable Bolt.....	44	Resin Capsules.....	77
21.8mm Barrel & Wedge.....	45	<b>PVC CANOPY TUBE SYSTEM</b>	
Grout Guns.....	46	PVC Drainage and Ground Consolidation System.....	79
Grout Lance - Screw In.....	47		
Grout and Breather Tube.....	48		
Tiger Dollie.....	49		
Dolly To 21.8mm Superstrand.....	50		
<b>FIBREGLASS CUTTABLE SYSTEMS</b>			
32mm Fibreglass Bolt.....	52		
25mm High Capacity Fibreglass Dowel.....	53		
32mm Fibreglass Hollow Face Dowel/SDA.....	54		
32mm GEODOWEL.....	55		

# DOUBLE CORROSION PROTECTION ROCK BOLTS & CABLES

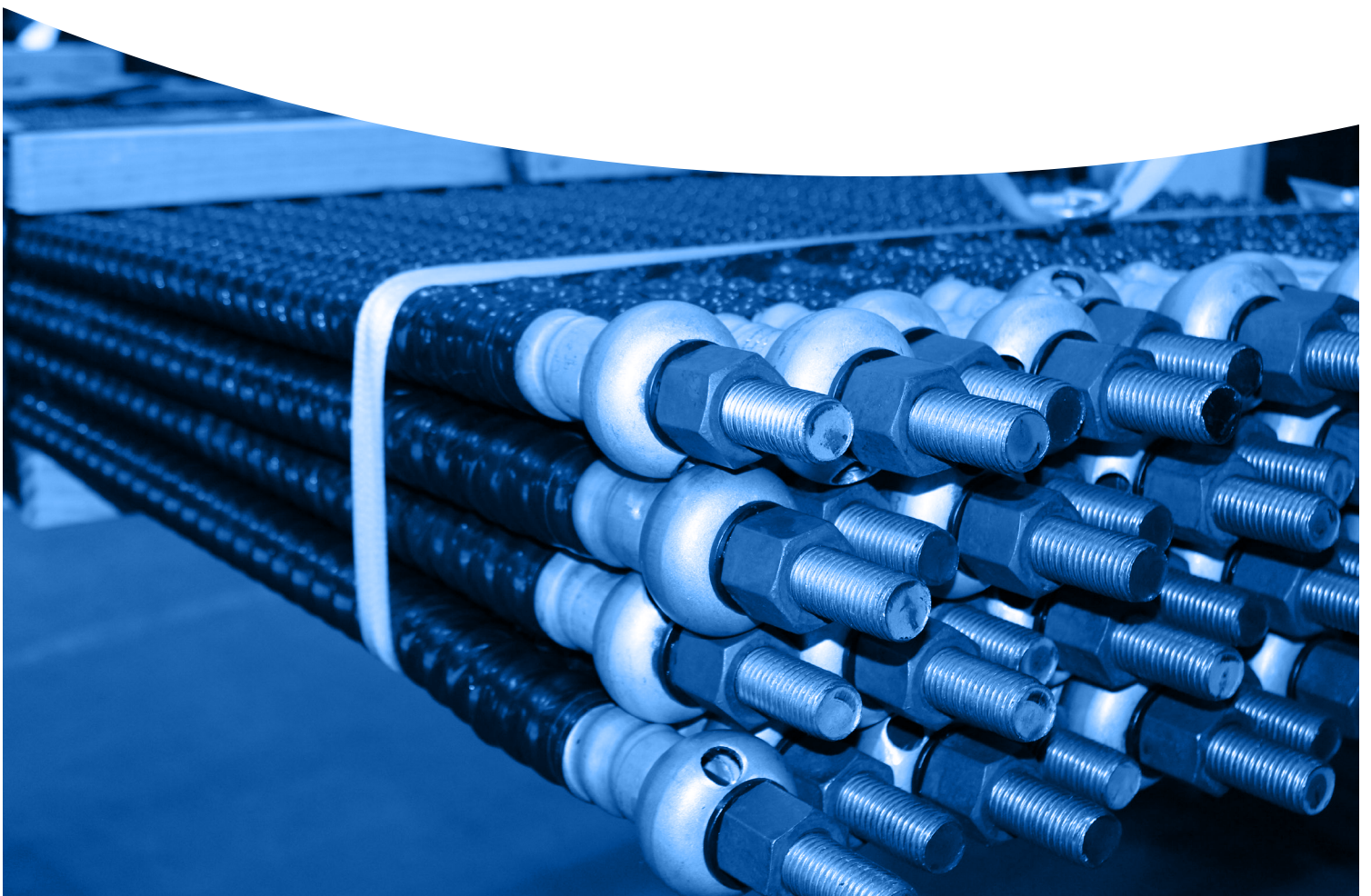

# Double Corrosion Rock Bolts & Cables

## SR Bolt



### Features:

- The SR Bolt rock bolt is a mechanical point anchored, pre tensioned, post groutable rock bolt with a grout injection head connection
- Typical applications include major civil engineering projects, such as tunneling and slope stability, as well as life-of-project infrastructure in the mining industry
- Fully automated or manual installation
- M24 "X" grade steel bar Gr. 650/890MPa, supplied by JENNMAR has superior toughness and ductility through the use of grain refining alloys. The Jenmar "X" grade bolts should provide better performance in mines where Stress Corrosion Cracking is evident and also in areas of high localized horizontal stresses
- The expansion shell capable of pre-tensioning bolt to 50kN prior to grouting
- Fully encapsulated in high-strength thixotropic grout
- Durable, high-density polyethylene (HDPE), sheath provides superior corrosion protection achieving a 100 year design life
- Recommended for drill hole size 43-45mm diameter
- Screw on adaptor available for grouting through the head connection
- Face plate and grout bell available in black and grade 316 stainless steel. Dissimilar metals are electrically isolated to prevent corrosion
- Bars can be supplied black or galvanised
- Standard lengths are available up to 9.0m

- Continued



# Double Corrosion Rock Bolts & Cables

## SR Bolt - Continued

### SR Rock Bolt:

Property	Minimum Value	Typical Value
Yield strength (kN)	228	246
Ultimate Tensile strength (kN)	310	348
Shear Strength (kN)	213	243
Elongation %	15	19
Bar core diameter (mm)	21.5	21.7
Cross sectional area (mm <sup>2</sup> )	363	378
Mass/meter (kg/m)	2.8	3.0
Drill Hole size (mm)	-	43-45

### SR Rock Bolt Sheath:

Property	Test Method	Cell Class	Acceptance Criteria	Test Results
Density	ASTM D1505	3	>0.940-0.947 g/cm <sup>3</sup>	0.948 g/cm <sup>3</sup>
Melt Index	ASTM D1238	3	<0.4-0.15 g/ 10 min	0.3g/10 min
Flexural Modulus	ASTM D790	5	758-1103 MPa	790 MPa
Tensile Strength	ASTM D638	4	21-24 MPa	22.9MPa
Slow Grout Crack Resistance	ASTM D638 / ASTM F1473	3	Test Condition - C duration - 192 h; Max. Failure rate - 20%	Failure Rate - 0% Duration - 200 h
Hydrostatic Strength Classification	ASTM D2837	0	-	-
Colour		C	2.0%-3.0 % Carbon Black	2.0%-3.0% Carbon Black
Softening point (BS 2782:part 1)	BS 2782:part 1		>110 C	120 C
Hardness (Shore D)	BS 2782: part 1		>50	55
Water Absorption at 23 C	ASTM D570		<0.5%	0.2%

## Double Corrosion Rock Bolts & Cables

### Low Profile Double Corrosion Protection Rock Bolt



#### Features:

- The low profile DCP rock bolt is a mechanical point anchored, pre tensioned, post groutable, low profile rock bolt with a grout injection head connection.
- Typical applications include major civil engineering projects, such as tunneling and slope stability, as well as life-of-project infrastructure in the mining industry
- Fully automated or manual installation
- M24 "X" grade steel bar Gr. 650/890MPa, supplied by JENNMAR has superior toughness and ductility through the use of grain refining alloys. The Jenmar "X" grade bolts should provide better performance in mines where Stress Corrosion Cracking is evident and also in areas of high localized horizontal stresses
- The unique, low profile nut design significantly reduces bolt tail protruding from excavation face
- Provision for in-situ proof load testing
- The expansion shell capable of pre-tensioning bolt to 50kN prior to grouting
- Fully encapsulated in high-strength thixotropic grout
- Durable, high-density polyethylene (HDPE), corrugated sheath provides superior corrosion protection achieving a 100 year design life
- Corrugations in sheathing provide excellent load transference between inner and outer grout annuli
- Recommended for drill hole size 48-51mm diameter
- Screw on adaptor available for grouting through the head connection
- Bolt can be supplied black or galvanised. Face plate and grout bell available in Gr. 316 stainless steel and are electrically isolated from dissimilar metals to prevent galvanic corrosion
- All standard lengths are available and any length can be produced upon request

- Continued

# Double Corrosion Rock Bolts & Cables

## Low Profile Double Corrosion Protection Rock Bolt - *Continued*

### LP Rock Bolt:

Property	Minimum Value	Typical Value
Yield strength (kN)	228	246
Ultimate Tensile strength (kN)	310	348
Shear Strength (kN)	213	243
Elongation %	15	19
Bar core diameter (mm)	21.5	21.7
Cross sectional area (mm <sup>2</sup> )	363	378
Mass/meter (kg/m)	2.8	3
Drill Hole size (mm)	45	-

### LP Rock Bolt Sheath:

Property	Test Method	Cell Class	Acceptance Criteria	Test Results
Density	ASTM D1505	3	>0.940-0.947 g/cm <sup>3</sup>	0.948 g/cm <sup>3</sup>
Melt Index	ASTM D1238	3	<0.4-0.15 g/10 min	0.3g/10 min
Flexural Modulus	ASTM D790	5	758 - 1103 MPa	790 MPa
Tensile Strength	ASTM D638	4	21-24 MPa	22.9MPa
Slow Grout Crack Resistance	ASTM D638 / ASTM F1473	3	Test Condition - C duration - 192 h; Max. Failure rate - 20%	Failure Rate - 0% Duration - 200 h
Hydrostatic Strength Classification	ASTM D2837	3	8.62 MPa	8.62 MPa
Colour		C	2.0%-3.0 % Carbon Black	2.0%-3.0% Carbon Black
Softening point (BS 2782:part 1)	BS 2782:part 1		>110 C	120 C
Hardness (Shore D)	BS 2782: part 1		>50	55
Water Absorption at 23 C	ASTM D570		<0.5%	0.2%

Sheathing Corrugations must be uniform and generally sinusoidal in shape, conforming to the following:

1. Wall Thickness (w) of Ducts:  $w > 2\text{mm}$
2. Pitch of corrugations (p):  $6w \leq p \leq 12w$
3. Amplitude of corrugations (a):  $a > 3w$

The profile must not allow voids to be formed in the grout column

The Rock Bolt can be supplied Black or Hot Dipped Galvanised.

Plate is supplied in 316 Stainless steel in accordance with AS1449:1994 or equivalent and are electrically isolated from dissimilar metals to prevent galvanic corrosion.

Conformance Certificates provided for all Civil products

## Double Corrosion Rock Bolts & Cables

### DCP Cable Bolt - 21.8mm

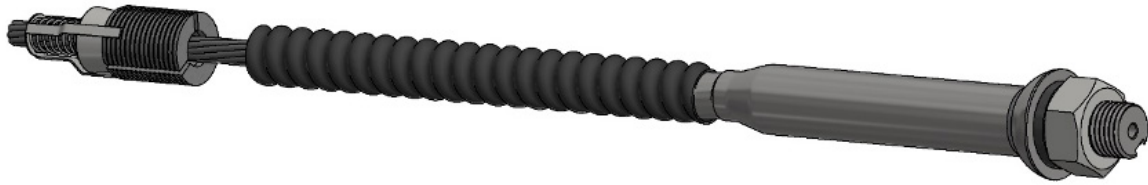

#### Features:

- Durable, high density, polyethylene (HDPE), corrugated sheath provides superior corrosion protection achieving a 100 year design life
- Corrugations in sheathing provide excellent load transference between inner and outer grout annuli
- Low profile head connection when compared to alternative barrel and wedge torque tension devices
- Fully encapsulated in high strength thixotropic grout
- Dome ball washer allows for plate/bolt angular misalignment up to 15 degrees
- Mechanical anchor allows cable to be pre-tensioned up to 50kN
- Cable is flexible and easy to handle in tight working areas due to the multi-strand construction
- Easily accessible for post-installation testing
- Grout bell and face plates are available in Gr. 316 stainless steel for superior corrosion resistance
- Face plates available with handle bars to allow shear connection with shotcrete lining
- Available in lengths up to 12.0m
- Typical lengths: 5.5-9.0m

- Continued

# Double Corrosion Rock Bolts & Cables

## DCP Cable Bolt – 21.8mm – *Continued*

### Cable

Cable diameter (mm)	Yield Strength (kN)	Breaking Load (kN)	Elongation at Failure (%)	Drill Hole Size (mm)
18.0 (7 Wires)	289	360	>3.5	57
21.8 (19 Wires)	525	590	>3.5	64

### Cable Sheath

Property	Test Method	Cell Class	Acceptance Criteria	Test Results
Density	ASTM D1505	3	>0.940-0.947 g/cm <sup>3</sup>	0.948 g/cm <sup>3</sup>
Melt Index	ASTM D1238	3	<0.4-0.15 g/ 10 min	0.3g/10 min
Flexural Modulus	ASTM D790	5	758-1103 MPa	790 MPa
Tensile Strength	ASTM D638	4	21-24 MPa	22.9MPa
Slow Grout Crack Resistance	ASTM D638 / ASTM F1473	3	Test Condition – C duration – 192 h; Max. Failure rate – 20%	Failure Rate – 0% Duration – 200 h
Hydrostatic Strength Classification	ASTM D2837	3	8.62 MPa	8.62 MPa
Colour		C	2.0%-3.0 % Carbon Black	2.0%-3.0% Carbon Black
Softening point (BS 2782:part 1)	BS 2782:part 1		>110 C	120 C
Hardness (Shore D)	BS 2782: part 1		>50	55
Water Absorption at 23 C	ASTM D570		<0.5%	0.2%

Sheathing Corrugations must be uniform and generally sinusoidal in shape, conforming to the following:

1. Wall Thickness (w) of Ducts:  $w > 2\text{mm}$
2. Pitch of corrugations (p):  $6w \leq p \leq 12w$
3. Amplitude of corrugations (a):  $a > 3w$

The profile must not allow voids to be formed in the grout column

Face Plate and Grout bell are supplied in 316 Stainless steel in accordance with AS1449:1994 or equivalent and are electrically isolated from dissimilar metals to prevent galvanic corrosion.

Mechanical anchor allows the cable to be pre-tensioned up to 50kN Cable Bolt.

Conformance Certificates provided for all

## Double Corrosion Rock Bolts & Cables

### DCP Cable Bolt – 18mm

The DCP Cable Bolt is a specially designed permanent, flexible rock anchor which is capable of fully mechanized and remote installation. The anchor features a mechanical anchor and threaded head connection enabling point anchorage and pre-tensioning at the excavation site. A robust high density polyethylene sheathing not only provides excellent corrosion protection, giving the anchor a 100 year design life, but also facilitates top-down grouting.



#### Features:

- Durable, high density, polyethylene (HDPE), corrugated sheath provides superior corrosion protection achieving a 100 year design life
- Corrugations in sheathing provide excellent load transference between inner and outer grout annuli
- Low profile head connection when compared to alternative barrel and wedge torque tension devices
- Fully encapsulated in high strength thixotropic grout
- Dome ball washer allows for plate/bolt angular misalignment up to 15 degrees
- Mechanical anchor allows cable to be pre-tensioned up to 50kN
- Cable is flexible and easy to handle in tight working areas due to the multi-strand construction
- Easily accessible for post-installation testing
- Grout bell and face plates are available in Gr. 316 stainless steel for superior corrosion resistance
- Face plates available with handle bars to allow shear connection with shotcrete lining
- Available in lengths up to 12.0m
- Typical lengths: 5-7m

- Continued

# Double Corrosion Rock Bolts & Cables

## DCP Cable Bolt – 18mm - *Continued*

### Cable

Cable diameter (mm)	Yield Strength (kN)	Breaking Load (kN)	Elongation at Failure (%)	Drill Hole Size (mm)
18.0 (7 Wires)	289	360	>3.5	57/64

Cable Shear (0.85 x UTS)

### Cable Sheath

Property	Test Method	Cell Class	Acceptance Criteria	Test Results
Density	ASTM D1505	3	>0.940-0.947 g/cm <sup>3</sup>	0.948 g/cm <sup>3</sup>
Melt Index	ASTM D1238	3	<0.4-0.15 g/ 10 min	0.3g/10 min
Flexural Modulus	ASTM D790	5	758-1103 MPa	790 MPa
Tensile Strength	ASTM D638	4	21-24 MPa	22.9MPa
Slow Grout Crack Resistance	ASTM D638 / ASTM F1473	3	Test Condition – C Duration – 192 h; Max. Failure rate – 20%	Failure Rate – 0% Duration – 200 h
Hydrostatic Strength Classification	ASTM D2837	3	8.62 MPa	8.62 MPa
Colour		C	2.0%-3.0 % Carbon Black	2.0%-3.0% Carbon Black

Sheathing Corrugations must be uniform and generally sinusoidal in shape, conforming to the following:

1. Wall Thickness (w) of Ducts:  $w > 2\text{mm}$
2. Pitch of corrugations (p):  $6w \leq p \leq 12w$
3. Amplitude of corrugations (a):  $a > 3w$

The profile must not allow voids to be formed in the grout column

Face Plate and Grout bell are supplied in 316 Stainless steel in accordance with AS1449:1994 or equivalent and are electrically isolated from dissimilar metals to prevent galvanic corrosion.

Mechanical anchor allows the cable to be pre-tensioned up to 50kN Cable Bolt.

Conformance Certificates provided for all Civil products

# Double Corrosion Rock Bolts & Cables

## Grout Lance To Suit M24 SR Bolt

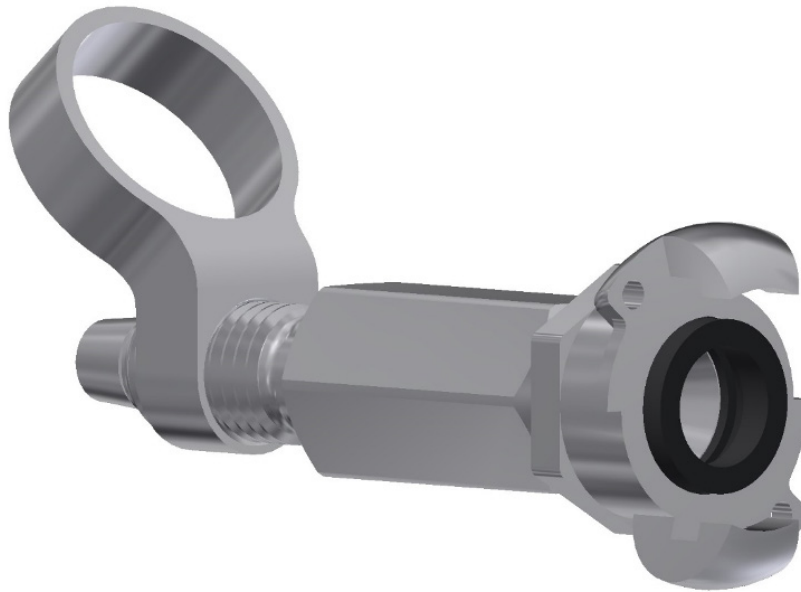

### Features:

- Screw on manual post grouting adaptor through the head connection
- Safely removes operators from exposure while grouting

Length (mm)	Thread Connection	Adjustment Length (mm)
120	3/4" BSP	50



## Double Corrosion Rock Bolts & Cables

### Grout Nozzle To Suit M24 Low Profile Bolt

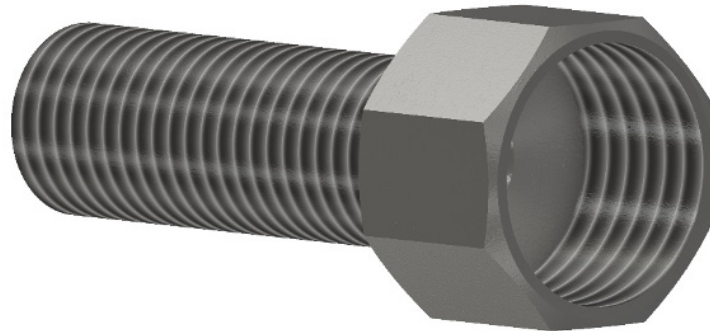

#### Features:

- Screw on manual post grouting adaptor
- Safely removes operators from exposure while grouting

Length (mm)	Grouting Thread Connection	Connecting Thread LH
107	1" BSP	M24

## Double Corrosion Rock Bolts & Cables

### Grout Head To Suit 22mm DCP Cable Bolt



**Features:**

- Screw on manual post grouting adaptor
- Safely removes operators from exposure while grouting

Length (mm)	Grouting Thread Connection	Adjustment Length (mm)	Thread (mm)
160	1" BSP	80	M48

MM\_DCPGA\_M48WCXGROUtheadCVL-Rev0

### Grout Head To Suit 18mm DCP Cable Bolt



**Features:**

- Screw on manual post grouting adaptor
- Safely removes operators from exposure while grouting

Length (mm)	Grouting Thread Connection	Adjustment Length (mm)	Thread (mm)
160	1" BSP	80	M36

MM\_DCPGA\_M36WCXGROUtheadCVL-Rev0

# TEMPORARY ROCK BOLTS

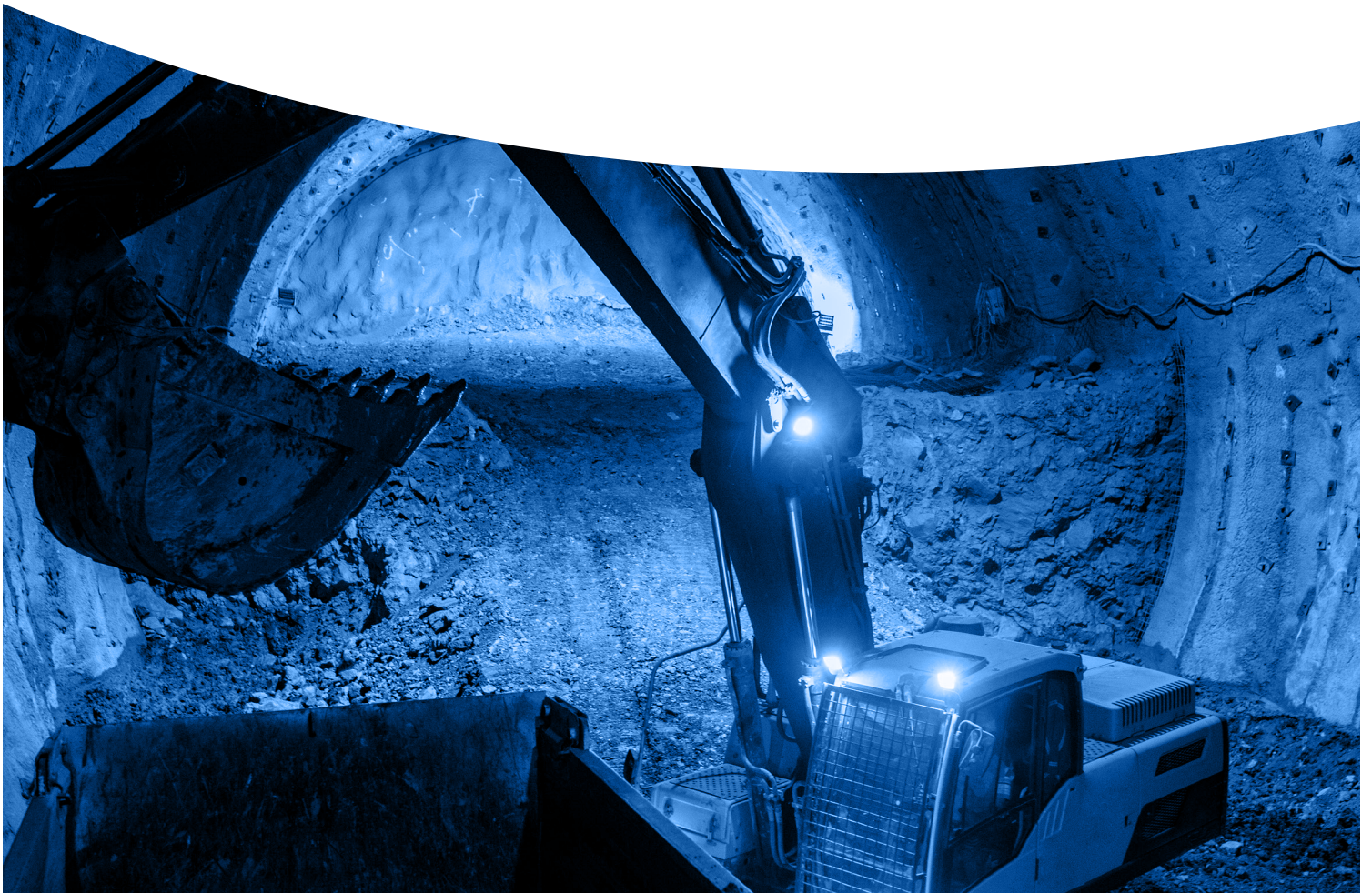

## Temporary Rock Bolts

### J-Tech® 20mm All Thread Bolt



#### Features:

- 20mm Left hand thread bar (10mm Pitch)
- Suitable for use with either resin capsules or grout
- Pin Nut System available for resin bolting installation
- Offers excellent load transfer
- Resin shredder actively promotes shredding of the capsule file and mixing of the resin components
- Resin shredder centralizes the bolt within the borehole and allows use in larger diameter holes e.g. 35mm – 40mm
- Paddle resin mixing device actively promotes resin mixing and anchorage in smaller hole diameters
- Available in plain or hot dipped galvanized. (Epoxy coating available on request)
- Dome nut design allows angular installation of up to 15 degrees
- Nut design requires the use of a standard 36mm A.F. tightening spanner
- Supplied with either Kanga, Volcano or flat plates
- T38 and hand held dolly drive assemblies available in any length
- Patent Pending Shredder

#### Applications:

- Concrete reinforcement Bar
- Spile Bar
- Ground Anchor
- Soil Nail
- Tie Rod

- Continued

# Temporary Rock Bolts

## J-Tech® 20mm All Thread Bolt - *Continued*

### 20mm Thread Bar

Property	Minimum Value MPa/kN	Typical Value MPa/kN
Yield strength (kN)	500/160	550/170
Ultimate Tensile strength (kN)	600/185	600/200
Shear Strength (kN)	130	140
Elongation %	15	19

Bar diameter (mm)	Core - 19.5	Major - 21.7
Bar Straightness to AS 1442-1991		
Cross Sectional Area (mm <sup>2</sup> )	300	
Mass Per Meter (kg/m)	2.47	
Drill Hole size Shredder (mm)	35 - 40	
Drill Hole size Paddle (mm)	32 - 38	
Thread Pitch (mm)	10	

Available Black or Hot Dipped Galvanised  
Conformance Certificates supplied with all Civil Products

J-TECH® is a registered trademark of FCI Holdings Delaware, Inc

#### Accessories:

- Hex nuts
- Dome nuts
- Couplers
- Hanger nuts rated to 2 tonnes
- Mechanical anchors
- Centralisers

## Temporary Rock Bolts

### J-Tech® 25mm All Thread Bolt



#### Features:

- Left hand thread bar
- Suitable for use with either resin capsules or grout
- Pin Nut System available for resin bolting installation
- Offers excellent load transfer
- Resin shredder actively promotes shredding of the capsule file and mixing of the resin components
- 40mm resin shredder available with bolt for 43 – 45mm drill
- Resin shredder centralizes the bolt within the borehole and allows use in larger diameter holes e.g. 43mm – 45mm
- Paddle resin mixing device actively promotes resin mixing and anchorage in smaller diameter holes e.g. 32mm – 38mm
- Dome nut design allows angular installation of up to 15 degrees
- Finer 6mm pitch thread achieves higher tension for a given torque
- Available in plain or hot dipped galvanized (Thermal diffusion and Epoxy available on request)
- Dynamic testing conducted without bolt failure to 47kJ absorbed energy
- Dome nut design allows the use of a standard 36mm A.F. tightening spanner
- Hanger nuts load rated at 2 and 3 tonne
- Supplied with Kanga plate which collapses when the bolt goes into yield
- T38 drive dollie available in any length

#### Applications:

- Concrete reinforcement Bar
- Spile Bar
- Ground Anchor
- Soil Nail
- Tie Rod

- Continued

# Temporary Rock Bolts

## J-Tech® 25mm All Thread Bolt - *Continued*

### 25mm Thread Bar

Property	Minimum Value MPa/kN	Typical Value MPa/kN
Yield strength (kN)	500/215	565/245
Ultimate Tensile strength (kN)	600/260	685/294
Shear Strength (kN)	182	206
Elongation %	15	20

Bar diameter (mm)	Core - 23	Major - 25
Bar Straightness to AS 1442-1991		
Cross Sectional Area (mm <sup>2</sup> )	433	
Mass Per Meter (kg/m)	3.4	
Drill Hole size Shredder (mm)	43 - 45	
Drill Hole size Paddle (mm)	32 - 38	
Thread Pitch (mm)	6	

Available Black or Hot Dipped Galvanised  
Conformance Certificates supplied with all Civil Products

J-TECH® is a registered trademark of FCI Holdings Delaware, Inc

#### Accessories:

- Hex nuts
- Dome nuts
- Couplers
- Hanger nuts rated to 2 and 3 tonnes
- Mechanical anchors
- Centralisers

# Temporary Rock Bolts

## Python Bolt



### Features:

- Suitable for common civil and hardrock drill hole diameters
- Lengths up to 6m
- Complete range of face plates to suit
- High pressure injection pumps and accessories are available.
- Specifically developed water injection dollie to fit Jumbo machines to allow percussion installation in collapsed holes and the ability to slide through centralisers
- Python Eye (PATENT PENDING) allows for easier insertion in damaged holes
- Specifically designed dollie and python eye allows for installation and inflation in collapsed drill holes and very poor ground.
- Pull rings available for site load testing

Specification Type	Tube Thickness (mm)	Inflated Bolt Diameter (mm)	Drill Hole Diameter (mm)	Minimum UTS (kN)	Mass/Metre
STANDARD	2	41	35-38	120	2kg/m
MINI	2	54	45-51	160	2.8kg/m
SUPER	3	54	45-51	240	3.75kg/m

The Inflation Friction Bolt can be supplied Black or Thermal Diffused Galvanised.  
Conformance Certificates provided for all Civil products.



# Temporary Rock Bolts

## Friction Lok Bolt

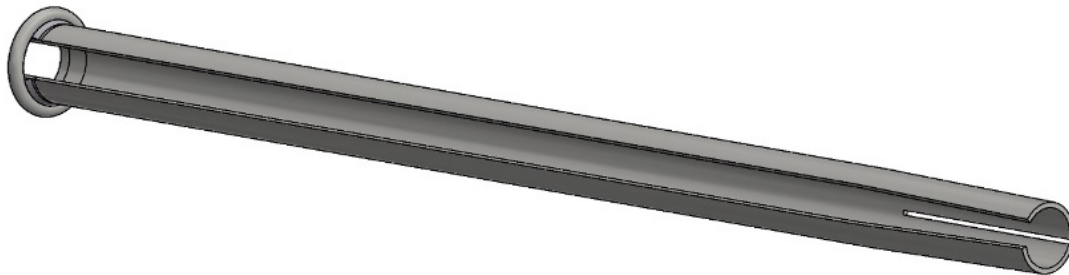

### Features:

- The radial compression of the slotted steel tube inside a borehole provides both radial and axial restraint to rock movement
- Can be post grouted for extra corrosion protection and support capacity
- Available in black or hot dipped galvanised
- 39mm Friction Lok designed to suit 47mm friction lok plates, requiring the use of one plate on site

### 33mm Friction Lok

Property	Minimum Value	Typical Value
Yield strength (kN)	80	100
Ultimate Tensile strength (kN)	100	120
Cross sectional area (mm <sup>2</sup> )	204	
Mass/meter (kg/m)	1.53	
Drill Hole size	30-32	
Welded Ring Integrity Test Min. (kN)	98	

The 33mm Friction Lok can be supplied Black or Hot Dipped Galvanised.  
Conformance Certificates provided for all Civil products.

- Continued

# Temporary Rock Bolts

## Friction Lok Bolt - *Continued*

### 39mm Friction Lok

Property	Minimum Value	Typical Value
Yield strength (kN)	90	115
Ultimate Tensile strength (kN)	115	135
Cross sectional area (mm <sup>2</sup> )	225	
Mass/meter (kg/m)	1.77	
Drill Hole size	35-38	
Welded Ring Integrity Test Min. (kN)	118	

MM\_FL\_JFL39CVL-Rev0

The 39mm Friction Lok can be supplied Black or Hot Dipped Galvanised.  
Conformance Certificates provided for all Civil products.

### 47mm Friction Lok

Property	Minimum Value	Typical Value
Yield strength (kN)	120	160
Ultimate Tensile strength (kN)	165	180
Cross sectional area (mm <sup>2</sup> )	355	
Mass/meter (kg/m)	2.79	
Drill Hole size	42-45	
Welded Ring Integrity Test Min. (kN)	157	

MM\_FL\_JFL47CVL-Rev0

The 47mm Friction Lok can be supplied Black or Hot Dipped Galvanised.  
Conformance Certificates provided for all Civil products.

# Temporary Rock Bolts

## M24 High Tensile Temporary Rock Bolt

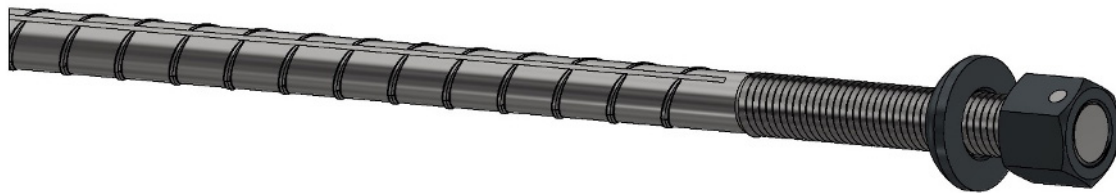

### Features:

- M24 “X” grade steel bar Gr. 650/890MPa, supplied by Jenmar has superior toughness and ductility through the use of grain refining alloys. The Jenmar “X” grade bolts should provide better performance in mines where Stress Corrosion Cracking is evident and also in areas of high localized horizontal stresses
- Recommended for drill hole sizes 27-29mm diameter when used with standard resin capsules
- Various roll pin break-out torque ranges available
- Can be installed with Resin or Cementitious Grout.
- Pin nut system available in a range of break out strengths
- Left hand thread required for most hard rock and civil installation
- Can be supplied fitted with either LH or RH mechanical anchor
- Suitable for both mechanized and Hand Bolting application

Property	Minimum Value	Typical Value
Yield strength (kN)	228	246
Ultimate Tensile strength (kN)	310	348
Shear Strength (kN)	213	243
Elongation %	15	19
Bar core diameter (mm)	21.5	21.7
Cross sectional area (mm <sup>2</sup> )	363	378
Mass/meter (kg/m)	2.8	3.0
Drill Hole size	27-29mm	

The M24 Rock Bolt can be supplied Black or Hot Dipped Galvanised.  
Conformance Certificates provided for all Civil products.

## Temporary Rock Bolt Accessories

### Expansion Shell M24 To Suit 45mm Hole RH

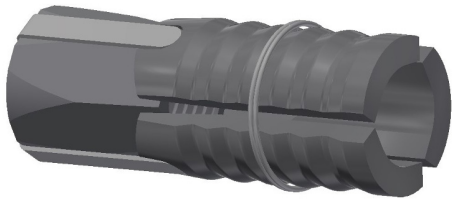

**Features:**

- Able to achieve tension to 50kN in competent ground
- Parallel contact of the expansion shell leafs in bore hole allows for excellent load transfer. Load testing should always be performed to determine the suitability of the anchor.
- Over drilling of the hole depth by a minimum 50mm ensures the expansion shell is correctly engaged with the bore hole

Thread type (mm)	Length (mm)	Mass (kg)	Hole Size (mm)	Minimum Pre Tension (kN)
M24 RH	115	0.6	45	50

MM\_ES\_ES2443RHTCVL-Rev0

Available Black or Hot Dipped Galvanised AS/NZS 4680:2006

### Expansion Shell M24 To Suit 45mm Hole LH

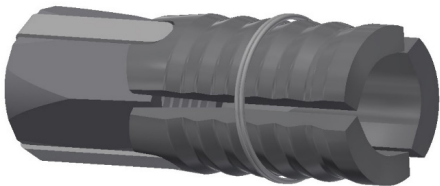

**Features:**

- Able to achieve tension to 50kN in competent ground
- Parallel contact of the expansion shell leafs in bore hole allows for excellent load transfer. Load testing should always be performed to determine the suitability of the anchor.
- Over drilling of the hole depth by a minimum 50mm ensures the expansion shell is correctly engaged with the bore hole

Thread type (mm)	Length (mm)	Mass (kg)	Hole Size (mm)	Minimum Pre Tension (kN)
M24 LH	115	0.6	45	50

MM\_ES\_ES2443LHTCVL-Rev1

Available Black or Hot Dipped Galvanised AS/NZS 4680:2006

### Expansion Shell M24 To Suit 51mm Hole LH

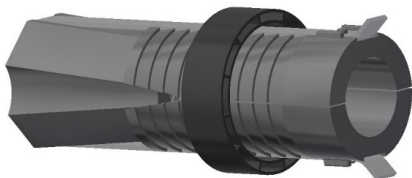

**Features:**

- Able to achieve tension to 50kN in competent ground
- Parallel contact of the expansion shell leafs in bore hole allows for excellent load transfer. Load testing should always be performed to determine the suitability of the anchor.
- Over drilling of the hole depth by a minimum 50mm ensures the expansion shell is correctly engaged with the bore hole

Thread type (mm)	Length (mm)	Mass (kg)	Hole Size (mm)	Minimum Pre Tension (kN)
M24 LH	135	0.75	51	50

MM\_ES\_ES2451LHTCVL-Rev0

Available Black or Hot Dipped Galvanised AS/NZS 4680:2006

# THREADBAR SYSTEM

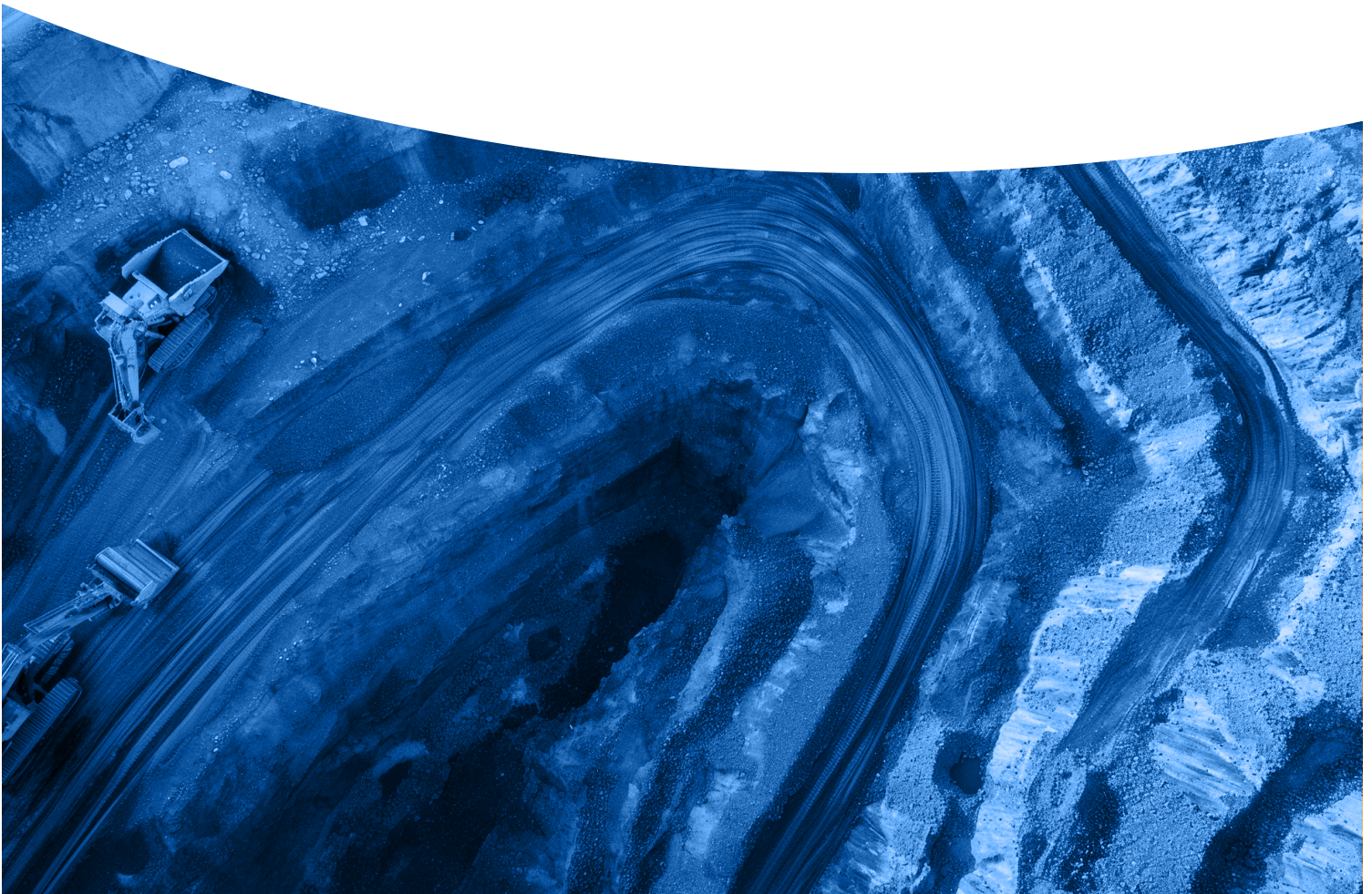

# JMA500N Threadbar System

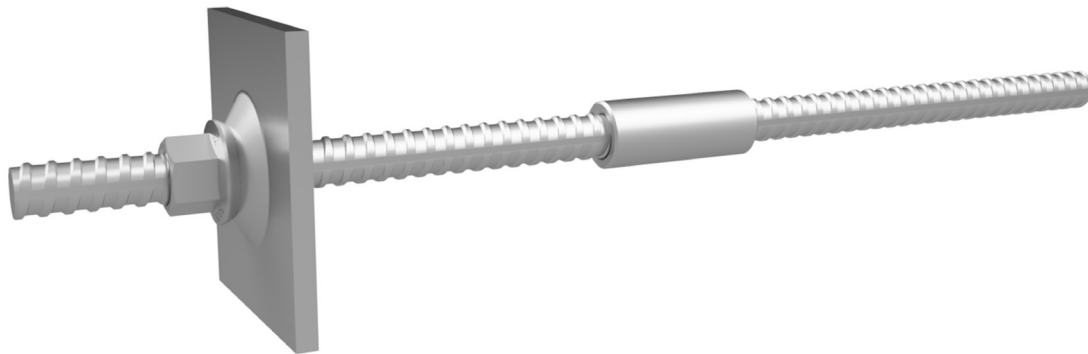

## Features:

- A robust continuous hot-rolled thread that can be cut and coupled with ease, offering maximum adaptability to varying lengths and depths
- Conforms with AS/NZS 4671 and certified by ACRS
- Available hot dip galvanised in accordance with AS/NZS 4680 for superior corrosion resistance
- Available in continuous lengths up to 12m

## Applications:

- Permanent & temporary soil nails
- Ground anchors
- Rock bolts
- Tie rods
- Micropiles
- Concrete reinforcement
- Cogged bars

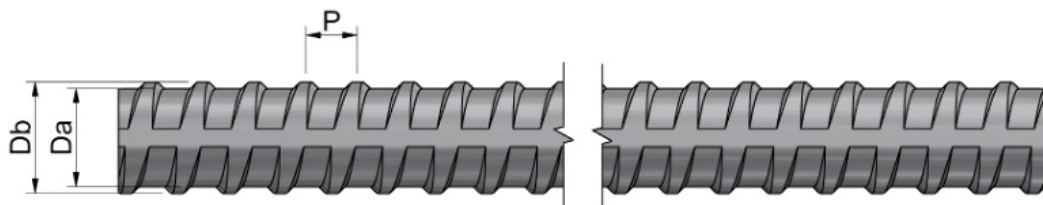

Property	Units	Value		
Steel Grade*	-	500N		
Norminal Diameter	mm	25	28	32
Yield Strength, $R_e$	MPa	500-650		
Minimum Ultimate Strength, $R_m$	MPa	550		
Minimum Yield Load	kN	246	308	402
Minimum Breaking Load	kN	270	339	442
Nominal Cross-Sectional Area	mm <sup>2</sup>	491	616	804
Nominal Core Diameter, $D_a$	mm	24.4	27.3	31.2
Nominal Thread Outer Diameter, $D_b$	mm	27.6	30.9	36.3
Thread Pitch, P	mm	12.5	14.0	16.0
Min. Uniform Elongation, $A_{gt}$	%	5		
Ratio $R_m/R_e$	-	1.08		
Unit Mass	kg/m	3.85	4.83	6.31
Thread Direction	-	Left-Handed		

\*conforms with AS/NZS 4671

# JMA500N Threadbar System

## Domed Nut

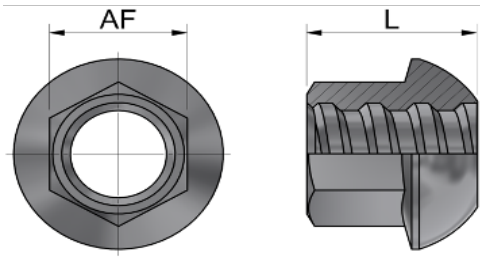

Property	Units	Value		
Nominal Bar Diameter (mm)	-	25	28	32
L	mm	45	54	57
AF	mm	41	41	46
Mass	kg	0.35	0.44	0.59
Strength/Capacity	-	Exceeds minimum/ Breaking strength of bar		

## Round Coupler

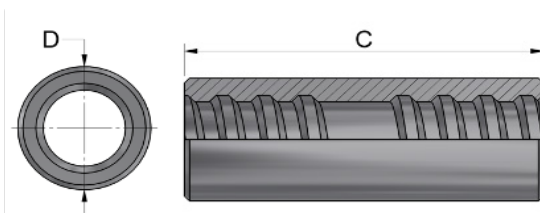

Property	Units	Value		
Nominal Bar Diameter (mm)	-	25	28	32
L	mm	45	54	57
AF	mm	41	41	46
Mass	kg	0.35	0.44	0.59
Strength/Capacity	-	Exceeds minimum/ Breaking strength of bar		

## Flat Plates

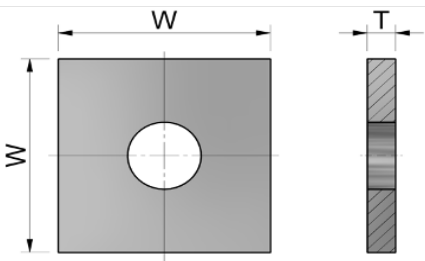

Property	Units	Value		
Nominal Bar Diameter (mm)	-	25	28	32
W	mm	150	200	200
T	mm	16	16	20
Mass	kg	2.7	4.87	5.95

Custom plate sizes are available upon request

## Domed Plates

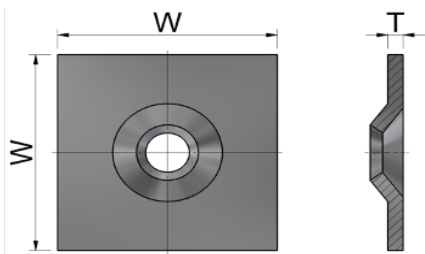

Property	Units	Value		
Nominal Bar Diameter (mm)	-	25	28	32
W	mm	150	200	200
T	mm	12	12	16
Mass	kg	2.07	3.72	4.91

Custom plate sizes are available upon request

### Other Accessories:

- Centralisers
- Plastic corrugated sheath
- Grout tube
- Grout gun
- End caps
- Stressing bars

# SELF DRILLING HOLLOW BOLTS & ACCESSORIES





# Self Drilling Hollow Bolts And Accessories

## Hollow Self Drilling Bolt

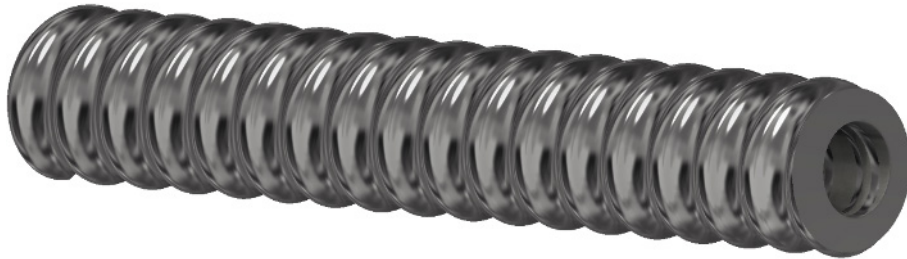

### Features:

- Installation using J-Lok P resin, PUR and grout
- Installation suited for very poor and unstable ground
- Corrosion resistant coatings available
- Reliable self-drilling installation with single pass drilling and grouting installation
- Wide range of drill bit types and diameters to suit ground conditions and design requirements
- Wide range of hollow bar diameters and capacities
- Available in a range of standard lengths with requested lengths available on request
- Ability to couple to required bolt lengths based on ground conditions and limited drilling area
- Continuous thread profile to enhance the ability of achieving better load transfer in varying ground conditions

### Applications:

- Ground Anchor
- Slope Stabilisation
- Micropile
- Roof and Rib Bolts
- Tie Backs
- Injection Bolts
- Foundation
- Ground Stabilisation
- Forepoling

- Continued

# Self Drilling Hollow Bolts And Accessories

## Hollow Self Drilling Bolt - *Continued*

Property	R25	R32N	R32S	R38N	R38S	R51N	R51S
Ultimate Tensile strength $\geq$ (kN)	200	280	360	500	550	800	950
Yield strength $\geq$ (kN)	150	230	280	400	430	630	760
Elongation $\geq$ (%)	8	8	8	8	8	8	8
Average Outside Diameter (mm)	25	32	32	38	38	51	51
Hollow Bar Internal diameter (mm)	12	19	17	22	18	33	31
Cross sectional area (mm <sup>2</sup> )	299	376	446	631	764	783	1070
Mass/meter (kg/m)	2.35	2.95	3.5	4.95	6	7.6	8.4
Thread Handing	LH	LH	LH	LH	LH	LH	LH
Available Lengths	1m, 2m, 3m, 4m, 6m						

\*Common sizes and capacities shown with other options available on request

Project based lengths available on request

\*Available in Black or Galvanised

\* Duplex Coating HDG and Epoxy available on request

\*Other Lengths are available on Request

\*\*“T” Thread Self Drilling Hollow bolts available on request

Conformance Certificates provided for all Civil products

# Self Drilling Hollow Bolts And Accessories

## Drilling Bit Accessories

DB SIZE	Drill Dia (mm)	Description/Application
EX		Hardened Cross Bit/ Sands, Fills, Gravel
R25/42	42	
R25/51	51	
EXXC		TC Cross Bit/Softer Sedimentary Rocks, Marls, Mudstone, Siltstone
R25/42	42	
R25/51	51	
ES		Hardened Button Bit/ Gravel, Soft Rock
R25/42	42	
R25/51	51	
ESS		TC Button Bit/Weathered Rock, Stone Walls, Rubble
R25/42	42	
R25/51	51	
EX		Hardened Cross Bit/ Sands, Fills, Gravel
R32/42	42	
R32/51	51	
R32/76	76	
EXXC		TC Cross Bit/Softer Sedimentary Rocks, Marls, Mudstone, Siltstone
R32/42	42	
R32/51	51	
R32/64	64	
R32/76	76	
ES		Hardened Button Bit/ Gravel, Soft Rock
R32/42	42	
R32/51	51	
R32/64	64	
R32/76	76	
ESS		TC Button Bit/Weathered Rock, Stone Walls, Rubble
R32/51	51	
R32/64	64	
R32/76	76	
EX		Hardened Cross Bit/ Sands, Fills, Gravel
R38/76	76	
R38/90	90	
R38/100	100	
EXXC		TC Cross Bit/Softer Sedimentary Rocks, Marls, Mudstone, Siltstone
R38/76	76	
R38/90	90	
R38/100	100	
R38/115	115	

- Continued

# Self Drilling Hollow Bolts And Accessories

## Drilling Bit Accessories- *Continued*

DB SIZE	Drill Dia (mm)	Description/Application
ES		Hardened Button Bit/ Gravel, Soft Rock
R38/76	76	
R38/90	90	
R38/115	115	
ESS		TC Button Bit/Weathered Rock, Stone Walls, Rubble
R38/76	76	
R38/90	90	
R38/115	115	
EX		Hardened Cross Bit/ Sands, Fills, Gravel
R51/90	90	
R51/100	100	
R51/115	115	
R51/130	130	
R51/150	150	
EXXC		TC Cross Bit/Softer Sedimentary Rocks, Marls, Mudstone, Siltstone
R51/90	90	
R51/100	100	
R51/115	115	
R51/130	130	
R51/150	150	
ES		Hardened Button Bit/ Gravel, Soft Rock
R51/76	76	
R51/100	100	
R51/115	115	
R51/130	130	
ESS		TC Button Bit/Weathered Rock, Stone Walls, Rubble
R51/76	76	
R51/100	100	
R51/115	115	
R51/130	130	
R51/150	150	

\*Common Drill bit types and sizes shown with alternative drill bits and sizes available on request to suit the application

Conformance Certificates provided for all Civil products



# Self Drilling Hollow Bolts And Accessories

## Accessories

Item	Hex Size (mm)	Length (mm)	Outside Diameter (mm)	Suit Plate Hole Size (mm)	Weight (kg)	Thread Handing
R25 Hex Nut	41	35	-	30	0.23	LH
R25 Dome Nut	41	40	-	30	0.31	LH
R25 Coupler	-	150	36	-	0.68	LH
R25 Centralizer (Steel)	-	20	48	-	0.11	-
R32 Hex Nut	46	45	-	36	0.37	LH
R32 Dome Nut	46	45	-	36	0.38	LH
R32N Coupler	-	160	42	-	0.84	LH
R32S Coupler	-	190	42	-	1	LH
R32 Centralizer (Steel)	-	30	72	-	0.27	-
R38 Hex Nut	50	60	-	42	0.47	LH
R38 Dome Nut	52	60	-	42	0.61	LH
R38N Coupler	-	180	51	-	1.38	LH
R38S Coupler	-	200	51	-	1.55	LH
R38 Centralizer (Steel)	-	30	78	-	0.28	-
R51 Hex Nut	75	80	-	56	1.84	LH
R51 Dome Nut	75	80	-	56	1.82	LH
R51N Coupler	-	200	63	-	1.84	LH
R51S Coupler	-	220	63	-	2	LH
R51 Centralizer (Steel)	-	30	91	-	0.3	-

\*The Mechanical Properties of the nuts and couplers shown are designed to meet the ultimate load of the SDHB

\*Available in Black or Galvanised

\* Duplex Coating HDG and Epoxy available on request

\*PVC Centralizers available on request

Conformance Certificates provided for all Civil products



# CABLE BOLTS & ACCESSORIES



## Cable Bolts

### 100T Goliath Cable Bolt



#### Features:

- 100 tonne capacity cable bolt
- Highest capacity cable on the market but still maintains flexibility for manual handling during installation
- Pre-tensioning jacks available up to 30 tonne
- 80 tonne capacity high tensile plates are available in relatively light weight 14mm thick steel

#### Typical Applications:

- Goliath of any length can be readily installed with hand bolters and hydraulic rigs as a point anchored, pre-tensioned support
- The 4m Goliath can be fully encapsulated with resin installed alongside primary support at the face. Installation time between 6-8 minutes

Property	Typical Value
Strand diameter (mm)	28.6
Number wires	19
Wire type	smooth
Steel area (mm <sup>2</sup> )	532
Mass (kg/m)	4.2
Typical yield strength (kN)	850
Typical Ultimate tensile strength (kN)	970
Breaking load with barrel & wedge (kN)	785
Elongation %	5-7

To suit drill bit 35mm

Resin capsules available to obtain encapsulation length up to 4m

Conformance Certificates provided for all Civil products

## Cable Bolts

### 100T Bulbed Goliath Cable Bolt



#### Features:

- 100 tonne capacity cable bolt
- Highest capacity cable on the market but still maintains flexibility for manual handling during installation
- Bulbed Goliath offers higher capacity anchorage over shorter encapsulation length
- Pre-tensioning jacks available up to 30 tonne
- 80 tonne capacity high tensile plates are available in relatively light weight 14mm thick steel

#### Typical Applications:

- Bulbed Goliath of any length can be readily installed with hand bolters and hydraulic rigs as a point anchored, pre-tensioned support

Property	Typical Value
Strand diameter (mm)	28.6
Number wires	19
Wire type	smooth
Bulb diameter (mm)	35
Bulb spacing (mm)	300
Steel area (mm <sup>2</sup> )	532
Mass (kg/m)	4.2
Typical yield strength (kN)	850
Typical Ultimate tensile strength (kN)	970
Breaking load with barrel & wedge (kN)	785
Elongation %	5-7

To suit drill bit 42mm

Resin capsules available to obtain encapsulation length up to 2.5m

Conformance Certificates provided for all Civil products



# Cable Bolts

## 70T 12 Wire Sumo Cable Bolt



### Features:

- Higher 70 tonne capacity SUMO cable bolt
- 12 wires increases flexibility and capacity
- Large 14mm I.D. central flexible corrugated grout tube
- Increased flexibility makes handling in confined areas easier and reduces the risk of manual handling related injuries
- Standard 31mm diameter and hex drive to suit existing cable bolting accessories i.e. dollies, tensioners and grout lances
- Birdcaged along the entire length for maximum load transfer
- Smooth wires for optimum performance in shear
- Plated with new higher capacity 12mm thick volcano plates with grout indicator slots.
- Plates available for trussing
- Lengths available up to 14 m

Property	Typical Value
Strand diameter (mm)	31
Number wires	12
Wire type	smooth
Bulb diameter (mm)	36
Bulb spacing (mm)	500
Steel area (mm <sup>2</sup> )	362
Mass (kg/m)	3.5
Typical yield strength (kN)	640
Typical Ultimate tensile strength (kN)	705
Breaking load with barrel & wedge (kN)	640
Elongation %	5-7

To suit drill bit 42-45 mm

Conformance Certificates provided for all Civil products

## Cable Bolts

### 70T 10 Wire Hollow Cable Bolt



#### Features:

- 70 tonne capacity, 10 wires
- Smooth wires for improved strength against shearing
- Standard 31mm diameter and hex drive to suit existing cable bolt accessories i.e. dollies, tensioners and grout lances
- Birdcaged along entire length for maximum load transfer
- Point anchored with J-LOK “Post-Grout” resin capsules, specifically designed for mixing in larger drill holes
- Top-down grouted using thixotropic grout
- Plated with new higher capacity 12mm thick volcano plates with grout indicator slots. Available in 200x200mm and 300x300mm sizes.
- Plates available for trussing
- Lengths available up to 10m

Property	Typical Value
Strand diameter (mm)	31
Number wires	12
Wire type	smooth
Bulb diameter (mm)	36
Bulb spacing (mm)	500
Steel area (mm <sup>2</sup> )	362
Mass (kg/m)	3.5
Typical yield strength (kN)	640
Typical Ultimate tensile strength (kN)	705
Breaking load with barrel & wedge (kN)	640
Elongation %	5-7

To suit drill bit 42-45mm

Conformance Certificates provided for all Civil products

# Cable Bolts





## 31mm 70T SUMO TEX Cable



### Features:

- 70 tonne capacity, 12 wire hollow cable bolt
- Fully bulbed, smooth wire for both high axial and shear performance when fully grouted
- Eliminates the need for hazardous hydraulic tensioners
- 8-10 tonne pre-tension is achievable off most hydraulic bolting rigs
- The threaded TEX end fitting achieves full tensile capacity of the wires
- Light weight high capacity 12mm plates available

Property	Typical Value
Strand diameter (mm)	31
Number wires	12
Wire type	smooth
Bulb diameter (mm)	36
Bulb spacing (mm)	500
Steel area (mm <sup>2</sup> )	385
Mass (kg/m)	3.5
Typical yield strength (kN)	640
Typical Ultimate tensile strength (kN)	705
Breaking load with TEX end fitting (kN)	705
Elongation %	5-7

Cable length (m)	Colour code
4.0	
6.0	
8.0	
10.0	

To suit drill bit 42-45mm

# Cable Bolts

## Superstrand Cable Bolt



### Features:

- Flexible and easy to handle even around the tight working areas of bolting rigs and continuous miner platforms
- Plain SuperStrand of any length can be readily installed with hand bolters as point anchored, pre-tensioned support
- The 4m SuperStrand can be “fully encapsulated” with resin installed alongside primary support at the face. Installation time between 6–8 minutes
- Special “through-the-chuck” drill motors allow full resin encapsulation of SuperStrands up to 8m in length

Property	Typical Value
Strand diameter (mm)	21.8
Number wires	19
Wire type	smooth
Steel area (mm <sup>2</sup> )	313
Mass (kg/m)	2.5
Typical yield strength (kN)	525
Typical Ultimate tensile strength (kN)	290
Breaking load with barrel & wedge/ToTo (kN)	510
Elongation %	5-7

ToTo Diameter (mm)	ToTo Length (mm)	ToTo Torque:Tension Ratio (Nm: tonnes)
70	150	40:1

To suit drill bit 27-28mm

Resin capsules available to obtain encapsulation length up to 4m

## Cable Bolt Accessories

### 21.8mm Barrel & Wedge



**Features:**

- Domed barrels & wedges are used with volcano plates to achieve installation angles of up to 18 degrees
- All barrels & wedges have an oil film coating and are pre-packaged in strong 4 litre buckets for corrosion protection
- All barrels & wedges to be pretensioned to a minimum 8 tonnes to ensure the wedge teeth penetrate the strand to achieve maximum load capacity
- Suit 21.8mm Superstrand Cables
- Bucket lid colour = yellow

Cable Diameter (mm)	Barrel Length (mm)	Barrel Diameter (mm)	Qty/Bucket
22	60	58	10

# Cable Bolt Accessories

## Grout Guns



### Features:

- Pressure rated quick connection to poly grouting hose
- Easy to use even with heavy rubber grouting gloves
- Colour coded to suit the grout hose colour code

Suit Tube Diameter (mm)	Colour code	Rated Working Pressure (Bar)	Length (mm)	Unit Mass (kg)
16	Red	34.5	340	1.4
20	Yellow	34.5	340	1.4

## Cable Bolt Accessories

### Grout Lance - Screw In



**Features:**

- Suits common industry post groutable cable bolts
- Pressure rated
- Available with swivel to assist with screw in connection
- Available in length ranging from 200mm to 2000mm
- Available with either Minsup or Surelock fittings

Length (mm)	Thread Connection	Rated Working Pressure (Bar)
200 - 2000	½" BSP	200

# Cable Bolt Accessories

## Grout and Breather Tube

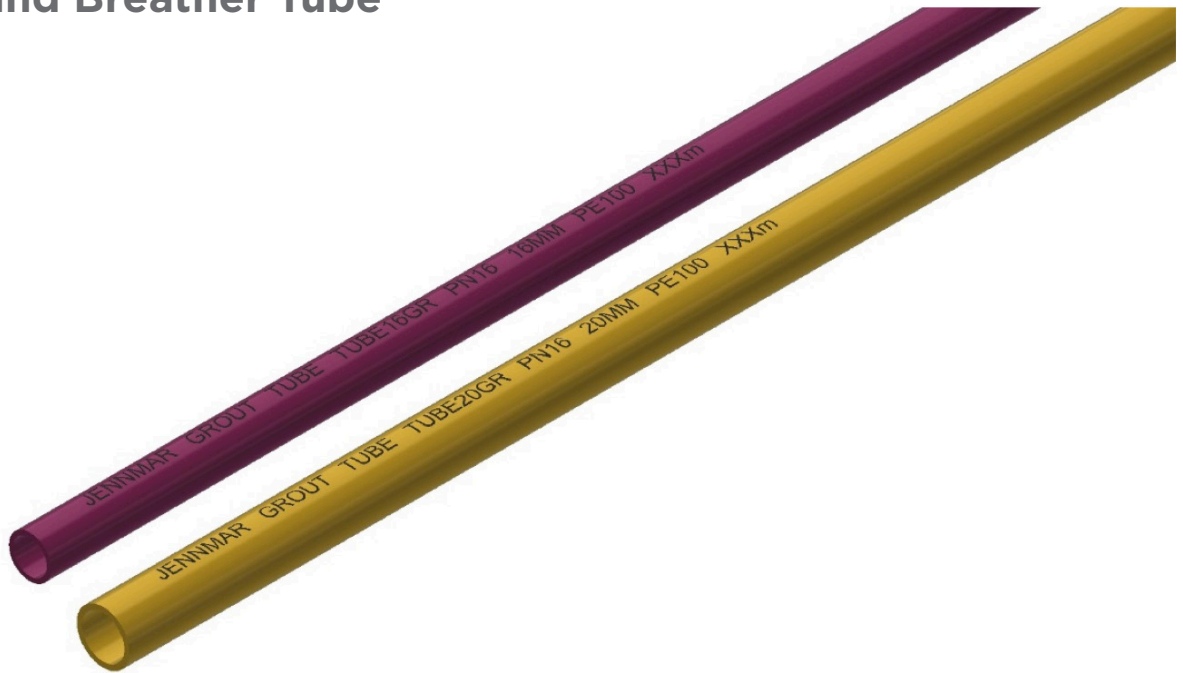

### Features:

- Pressure rated
- Available in rolls or cut to length

Tube O.D. (mm)	Tube I.D. (mm)	Pressure rating	Mass (kg/m)	Length per roll	Colour code
5	3	n/a	0.01	200	Yellow
16	12.5	PN16	0.07	300	Red
20	16	PN16	0.11	300	Yellow



## Cable Bolt Accessories

### Tiger Dollie

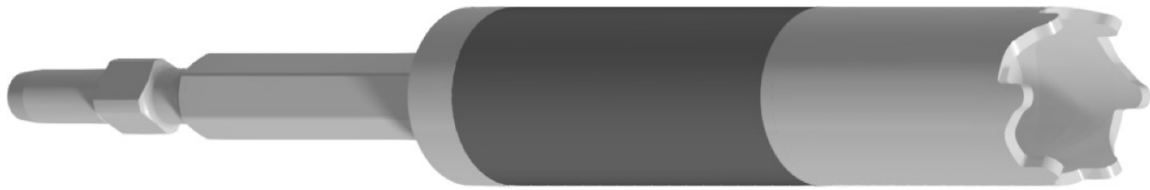

#### Features:

- Exclusively used for tensioning of the “TOTO” device
- Suitable for both TG “TOTO” and SuperStrand “TOTO”
- Locking square drive
- Hardened socket for long life
- Sealed components to prevent contaminants entering and interfering with spring function

Drive (mm)	Length (mm)	Maximum Diameter (mm)	Mass (kg)	Socket
25mm square	460	70	5.5	ToTo device

MM\_D\_JDOTIGER-Rev0

### Dolly To Suit 31mm 70T Sumo & Hollow Cable



#### Features:

- Use for installation of 70T SUMO and HOLLOW cables
- Internal hex drive with water flush cleaning feature
- 25mm locking square drive for use with common coal mining bolting rigs

Drive (mm)	Length (mm)	Cable drive (mm)
25 square	300-600	24.5 Hex

MM\_D\_JDO633531HBR-Rev0

## Cable Bolt Accessories

### Dolly To 21.8mm Superstrand



#### Features:

- Use for installation of 19 wire 21.8mm Superstrand Cables
- Additional 36 A.F. Hex allows dual purpose use on M24 rock bolts
- Internal flower drive with water flush cleaning feature
- 25mm locking square drive for use with common coal mining bolting rigs

Drive (mm)	Length (mm)	Cable drive	Socket (mm)
25 square	350	Superstrand	36 A.F.

MM\_D\_JDO6210350TWH-Rev0

### Dolly suit TEX cables

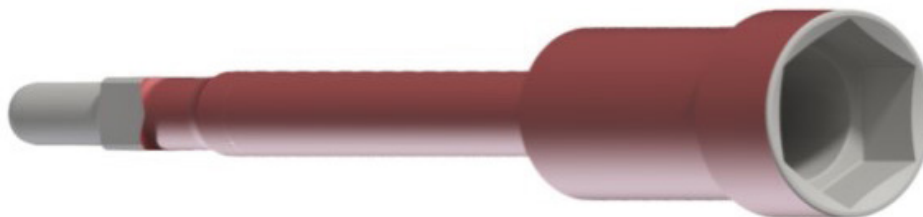

#### Features:

- Lightweight design
- Long spigot to suit standard rigs and those with lobster rollers
- 55mm A.F. Hex socket

Drive (mm)	Length (mm)	Cable drive (mm)
25 square	500	55 A.F.

MM\_D\_JDO650055TWH-Rev1

# FIBREGLASS CUTTABLE SYSTEMS



# Fibreglass Cuttable Systems

## 32mm Fiberglass Bolt



### Features:

- Used for Temporary face and rock support where extraction includes cutting of bolts
- Dome Nuts and couplers available
- Plates available in plastic and steel inserted plastic dome plates
- Continuous rope thread providing large deformations for increased bond strength
- Light weight and easy to install
- Single lengths available up to 11.8m long
- Plastic centralisers available to suit various hole sizes
- Thrust bolt system available with resin capsules
- 16mm and 20mm Grout tube available

### Applications:

- Soil nails
- Ground anchor
- Slope support
- Face dowels
- Rock bolt

Property	Minimum Value
Ultimate Tensile Strength (kN)	>500
Ultimate Tensile Strength with Nut (kN)	140
Ultimate Tensile Strength Coupler (kN)	320
Double Shear Strength (kN)	>220
Rod Torsional Strength (Nm)	230
Thread Pitch (mm)	10
Mass/Meter (kg/m)	1.45
Colour	Black

# Fibreglass Cuttable Systems

## 25mm High Capacity Fiberglass Dowel



### Features:

- Used for temporary face and rock support where extraction includes cutting of bolts
- Plastic dome nuts available
- Plastic and steel inserted plastic plates available
- Steel couplers available
- Continuous rope thread providing large deformations for increased strength
- Light weight and easy to install
- Single lengths available up to 11.8m long
- Plastic centralizers available to suit various hole sizes
- Can be installed with Resin Capsules
- Dowel Used with temporary DCP mechanical anchor bolt

### Applications:

- Soil nails
- Ground anchor
- Slope support
- Face dowels
- Rock bolt
- Temporary DCP mechanically anchored bolt

Property	Minimum Value
Ultimate Tensile Strength of Rod (kN)	>350
Ultimate Tensile Strength with Nut (kN)	70
Double Shear Strength (kN)	>140
Rod Torsional Strength (Nm)	>200
Thread Pitch (mm)	10
Mass/Meter (kg/m)	0.95

# Fibreglass Cuttable Systems

## 32mm Fiberglass Hollow Face Dowel/SDA



### Features:

- High Torsional self-drilling hollow post groutable fiberglass dowel
- Used for temporary face and rock support where extraction includes cutting of bolts
- Plastic and steel dome nuts available
- Plastic and steel inserted plastic plates available
- Steel couplers available
- Continuous rope thread providing large deformations for increased strength
- Light weight and easy to install
- Single lengths available up to 11.8m long
- Plastic and steel centralizers available to suit various hole sizes
- Various drill bits available

### Applications:

- Soil Nails
- Self-drilling post groutable face dowels
- Slope support
- Face Dowels
- Rock Bolts

Property	Minimum Value R32	Minimum Value R38	Minimum Value R51
Ultimate Tensile Strength of Rod (kN)	365	490	650
Rod Torsional Strength (Nm)	360	450	700
Thread type (ISO)	R32	R38	R51
Internal Diameter (mm)	15	20	33
Cross sectional area (mm <sup>2</sup> )*2	400	540	800
Tensile E-Modulus (GPa)	45	45	45
Ultimate Strain (%)	2.0	2.0	2.0
Mass/meter (kg/m)	0.99	1.33	1.98

# Cutable Support

## 32mm GEODOWEL



### Features:

- High capacity post groutable fibreglass dowel
- Used where coal extraction includes cutting of rib support dowels
- Suitable for use with common mine site cable bolting consumables:
  - 36mm diameter resin capsules
  - Cable bolt grouts
- 46mm Hex Nut
- Purpose designed installation spanners and grout connectors available
- Custom configurations are available including;
  - Resin anchored, tensioned, post grouted dowel
  - Simple fully grouted dowel
- Hollow dowels stocked in 3m and 4m lengths
- Do not store these products in direct sunlight

Property	Minimum Value
Ultimate Tensile Strength of Rod (kN)	500
Ultimate Tensile strength with Nut (kN)	160
Shear Strength (kN)	140
Rod Torsional Strength (Nm)	150
Elongation %	2
Cross sectional area (mm <sup>2</sup> )	610
Thread pitch (mm)	10
Mass/meter (kg/m)	1.3

Rod Colour	White
------------	-------

To suit drill bit 42-45mm

# PLATES





# Plates

## Plastic Plates: 22-25mm Dowels

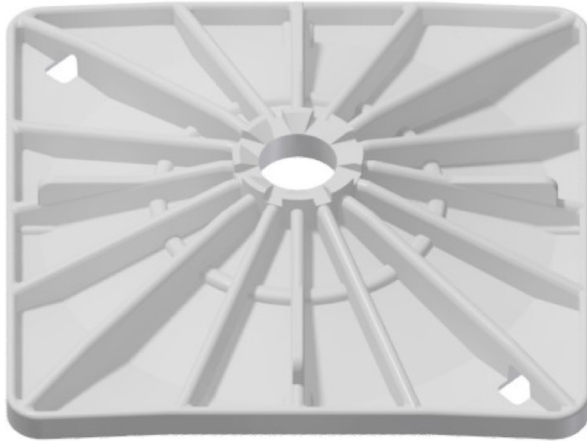

### Features:

- Used as coal rib surface support where extraction involved cutting the support
- Compatible with Jenmar 22mm dowels
- Flexibility of all plastic allow conforming to shape of uneven coal rib
- Tested to ensure no splitting under severe deformation found in uneven coal ribs
- Square plate is designed to visually turn corners upon applying hydraulic rib bolter thrust
- Do not store these in direct sunlight

Dimension (mm)	Hole diameter (mm)	Minimum Pull through load (kN)	Mass (kg)	Standard pack	Compatible Bolt dia (mm)
230 round	33	20	0.3	1000	22 and 25
230 square	33	12	0.3	1000	22 and 25

# Plates

## Kanga Plate to suit Temporary Rock Bolt

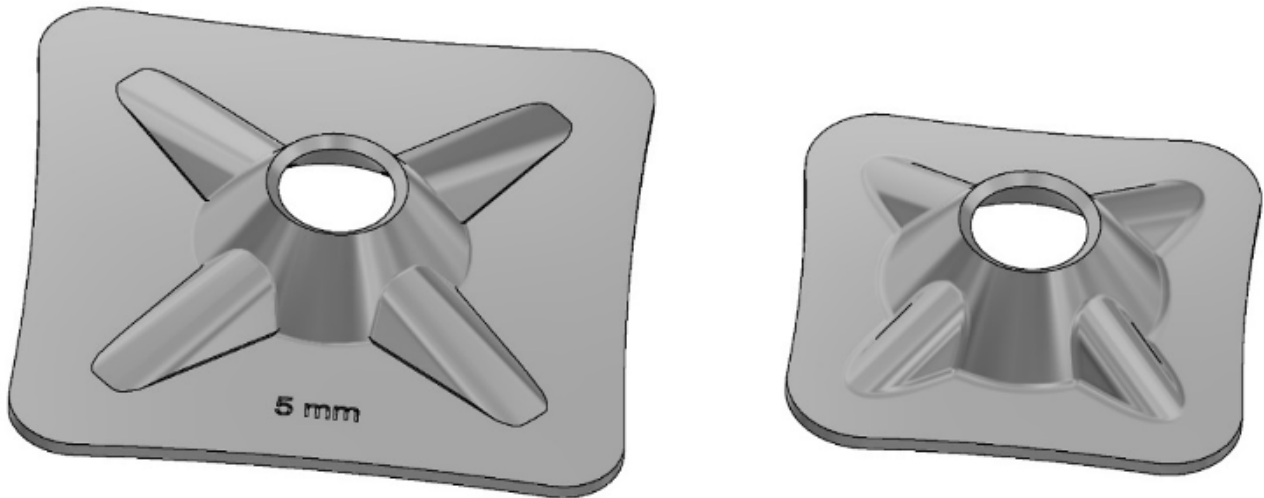

### Features:

- High load bearing characteristics
- Dome profile allows for 18° angles of alignment when installing the rock bolt with a domed ball washer or dome nut
- Light weight and rounded corners
- Lesser tendency to cut mesh upon loading
- Load rated hanger available to 50kg
- Available black or galvanised
- Varying combination plate applications available

Square dimension (mm)	Thickness (mm)	Hole diameter (mm)	Minimum Collapse load (kN)	Minimum Pull Through Load (kN)	Mass (kg)	Standard pack
150 x 150	5	38	201	201	0.85	980/pallet
200 x 200	5	38	201	201	1.53	500/pallet

Available with hanger slots  
 Available Black or Hot Dipped Galvanised  
 Conformance Certificates provided for all Civil products

# Plates

## Kanga Plate to suit Threaded and Temporary Rock Bolts

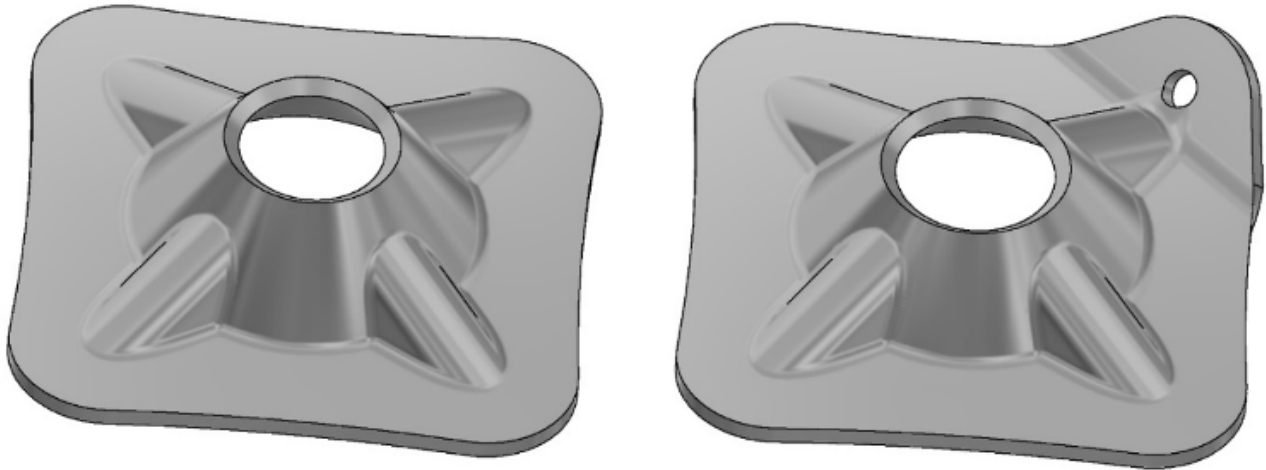

### Features:

- High load bearing characteristics
- Dome profile allows for 18° angles of alignment when installing the rock bolt with a domed ball washer or dome nut
- Light weight and rounded corners
- Lesser tendency to cut mesh upon loading
- Load rated hanger available to 50kg
- Available in black or galvanised
- Varying combination plate applications available

Square dimension (mm)	Thickness (mm)	Hole diameter (mm)	Minimum Collapse load (kN)	Minimum Pull Through load (kN)	Mass (kg)	Standard pack	Steel Grade
150 x 150	5	38	201	201	0.85	980/pallet	400
150 x 150	5	41	201	201	0.85	980/pallet	400
150 x 150	6	38	245	245	1.02	980/pallet	400

Available with hanger slots  
 Available Black or Hot Dipped Galvanised  
 Conformance Certificates provided for all Civil products

## Volcano Plate to suit 25mm Threaded Bolts

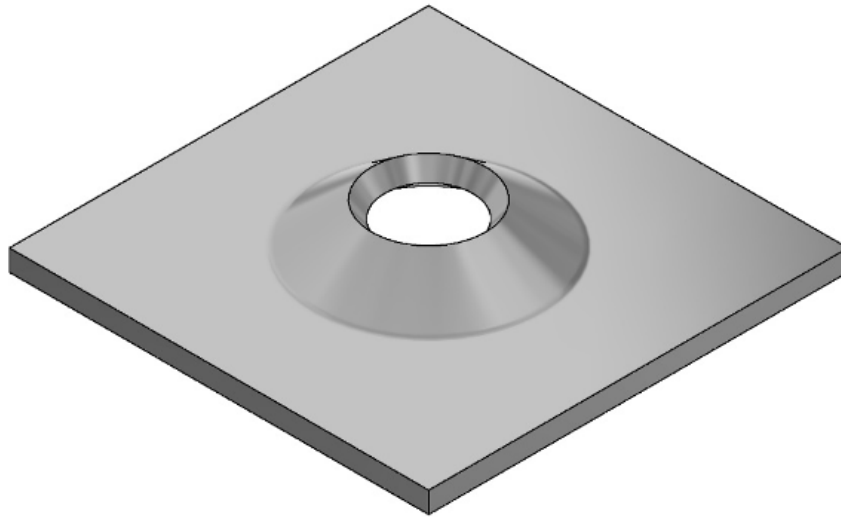

### Features:

- High load bearing characteristics
- Dome profile allows for 18° angles of alignment when installing the rock bolt with a domed ball washer or dome nut
- Available in black or galvanized
- Available in a wide range of thicknesses and dimensions

Dimension (mm)	Thickness (mm)	Hole diameter (mm)	Minimum Collapse Load (kN)	Minimum Pull through load (kN)	Mass (kg)	Standard pack	Steel grade
300 x 200	10	42	216	294	1.73	980	250

Material is in accordance with AS/NZS 1594 - HA250.  
 Available Black or Hot Dipped Galvanized  
 Conformance Certificates provided for all Civil products

## Plates

### Black Volcano Handle Bar Plate to Suit SR Bolt with Black Grout Bell

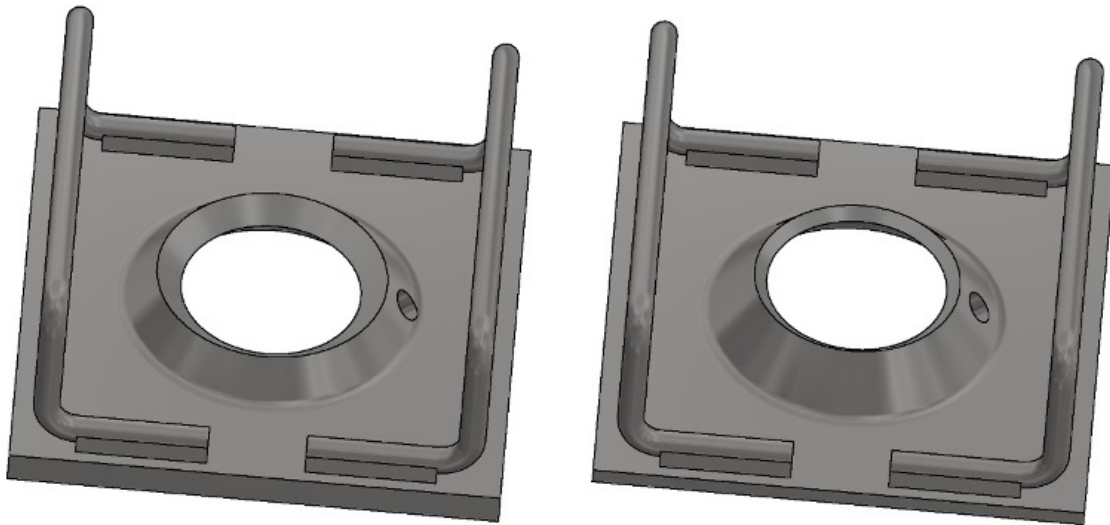

#### Features:

- High load bearing characteristics
- Dome profile allows for 15° angles of alignment when installing the SR rock bolt fitted with a black grout bell
- Plate supplied in black or galvanized
- Plate is supplied with a 10mm grout indicator hole

Dimension (mm)	Thickness(mm)	Hole diameter (mm)	Minimum Collapse Load (kN)	Minimum Pull through load (kN)	Mass (kg)	Standard pack	Steel Grade
150 x 150	5	55	216	275	1.14	420	350
150 x 150	10	55	216	295	1.91	420	250

Material is in accordance with AS3678-350 and AS/NZS 1594 - HA250 or equivalent  
 8mm 1030 grade Handle bars welded in accordance to AS1554  
 Conformance Certificates provided for all Civil Products

# Plates

## 316 SS Volcano Plate to suit SR Bolt with 316 SS Grout Bell

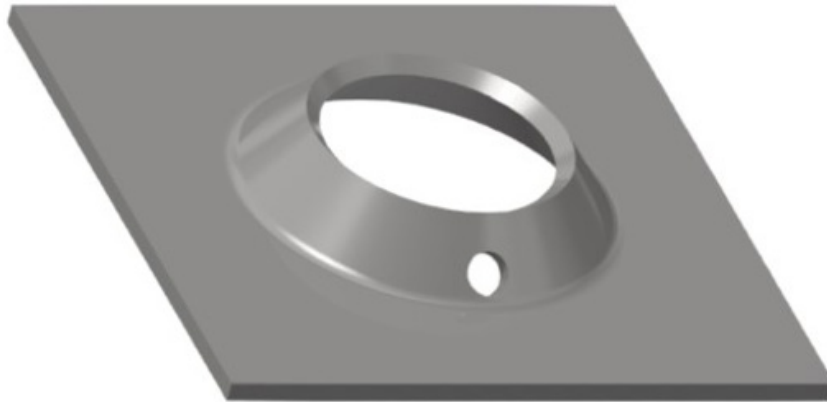

### Features:

- High load bearing characteristics
- Dome profile allows for 15° angles of alignment when installing the SR rock bolt fitted with a 316 Stainless Steel grout bell
- Plate supplied in 316 Stainless Steel
- Supplied with a 10mm grout indicator hole

Dimension (mm)	Thickness (mm)	Hole diameter (mm)	Minimum Collapse Load (kN)	Minimum Pull through load (kN)	Mass (kg)	Standard pack	Steel grade
150X150	5	55	216	275	0.862	1000	316

Material is in accordance with AS1449:1994 or equivalent  
 Conformance Certificates provided for all Civil Products

## Plates

### 316 SS Volcano Handle Bar Plate to suit SR Bolt with 316 SS Grout Bell



#### Features:

- High load bearing characteristics
- Dome profile allows for 15° angles of alignment when installing the SR rock bolt fitted with a 316 Stainless Steel grout bell
- Plate and handle bars Supplied in 316 Stainless Steel
- Plate is supplied with a 10mm grout indicator hole

Dimension (mm)	Thickness (mm)	Hole diameter (mm)	Minimum Collapse Load (kN)	Minimum Pull through load (kN)	Mass (kg)	Standard pack	Steel grade
150X150	5	55	216	275	1.14	420	316

Material is in accordance with AS1449:1994 or equivalent  
 8mm 316 SS Handle bars welded in accordance to AS1554  
 Conformance Certificates provided for all Civil Products

## Plates

### 316 SS Volcano Plate to suit Low Profile Bolt and the 18mm DCP Cable Bolt Both with 316 SS Grout Bell

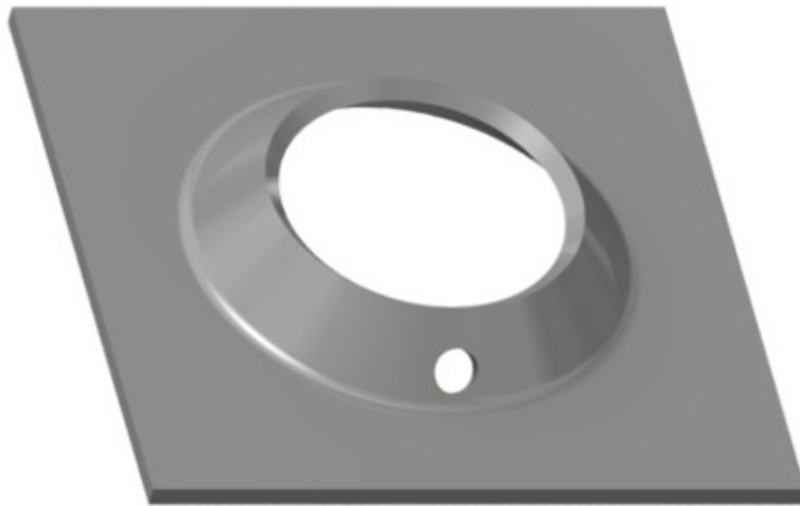

#### Features:

- High load bearing characteristics
- Dome profile allows for 15° angles of alignment when installing the Low Profile rock bolt or the 18mm DCP Cable Bolt fitted with a 316 Stainless Steel grout bell
- Plate supplied in 316 Stainless Steel
- Supplied with a 10mm grout indicator hole

Dimension (mm)	Thickness (mm)	Hole diameter (mm)	Minimum Collapse Load (kN)	Minimum Pull through load (kN)	Mass (kg)	Standard pack	Steel grade
150X150	5	64	216	275	0.862	1000	316

Material is in accordance with AS1449:1994 or equivalent  
Conformance Certificates provided for all Civil Products



## Plates

### 316 SS Volcano Handle Bar Plate to suit Low Profile Bolt and the 18mm DCP Cable Bolt Both with 316 SS Grout Bell



#### Features:

- High load bearing characteristics
- Dome profile allows for 15° angles of alignment when installing the Low Profile rock bolt or the 18mm DCP Cable Bolt fitted with a 316 Stainless Steel grout bell
- Plate and handle bars Supplied in 316 Stainless Steel
- Supplied with a 10mm grout indicator hole

Dimension (mm)	Thickness (mm)	Hole diameter (mm)	Minimum Collapse Load (kN)	Minimum Pull through load (kN)	Mass (kg)	Standard pack	Steel grade
150X150	5	64	216	275	1.10	420	316

Material is in accordance with AS1449:1994 or equivalent  
 8mm 316 SS Handle bars welded in accordance to AS1554  
 Conformance Certificates provided for all Civil Products

## Plates

### 316 SS Volcano Handle Bar Plate to Suit 22mm DCP Cable Bolt with 316 SS Grout Bell

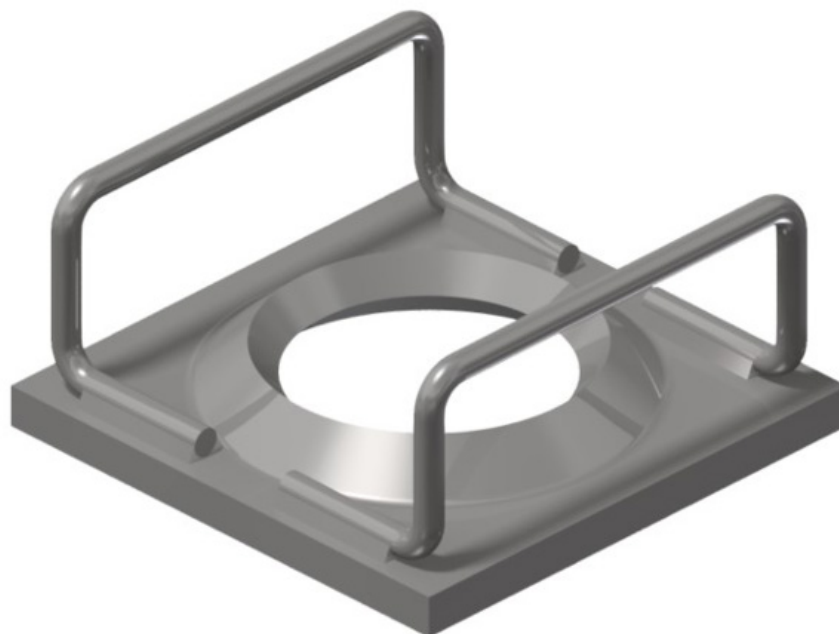

#### Features:

- High load bearing characteristics
- Dome profile allows for 15° angles of alignment when installing the 22mm DCP Cable Bolt fitted with a 316 Stainless Steel grout bell
- Plate and handle bars Supplied in 316 Stainless Steel
- Supplied with a 10mm grout indicator hole

Dimension (mm)	Thickness (mm)	Hole diameter (mm)	Minimum Collapse Load (kN)	Minimum Pull through load (kN)	Mass (kg)	Standard pack	Steel grade
150X150	12	76	540	638	2.05	420	316

Material is in accordance with AS1449:1994 or equivalent  
 8mm 316 SS Handle bars welded in accordance to AS1554  
 Conformance Certificates provided for all Civil Products

# Plates

## Roll Top Plate

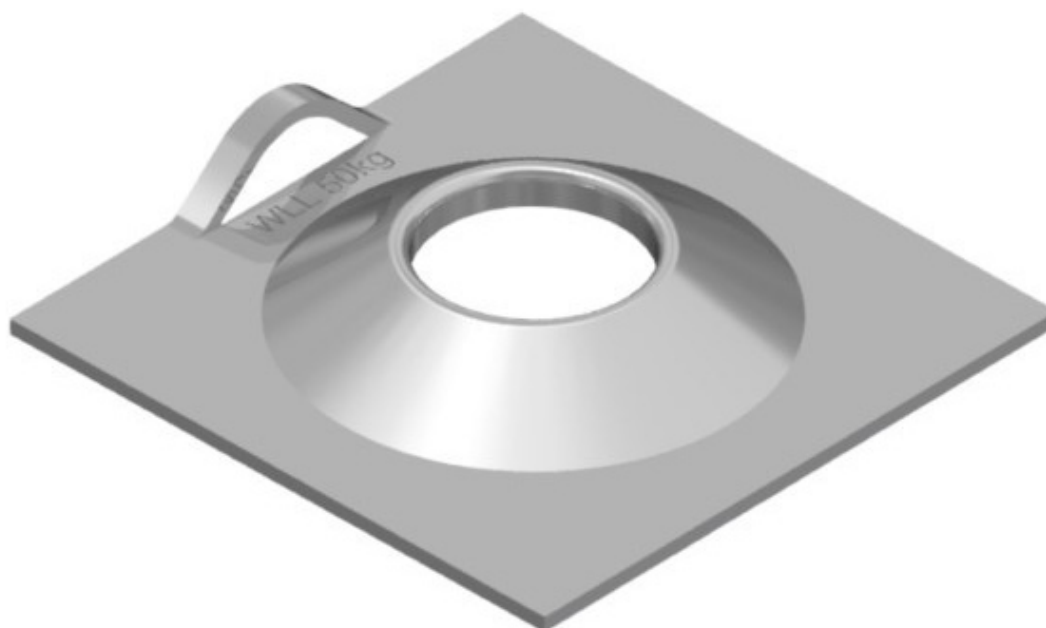

### Features:

- Designed to be used with 39 and 47mm diameter friction loks
- JENNMAR 39 and 47mm friction loks use the same roll top plate to reduce stock holding and for ease of installation
- Load rated hangars to 50kg WLL
- Can be supplied as a combination butterfly or pizza pan plate with 300mm and 450mm outside diameter
- Available in black, hot dipped galvanised or Armorgalv

Dimension (mm)	Thickness (mm)	Hole diameter (mm)	Minimum Collapse Load (kN)	Minimum Pull through load (kN)	Mass (kg)	Standard pack
150X150	4	50	98	118	0.711	980/pallet
200x200	4	50	98	118	1.33	500/pallet

Available in Black or Hot Dipped Galvanised  
 Suit 39 & 47mm Friction Lok Bolts  
 Conformance Certificates provided for all Civil products

# **SPECIALTY GROUT & CEMENT**

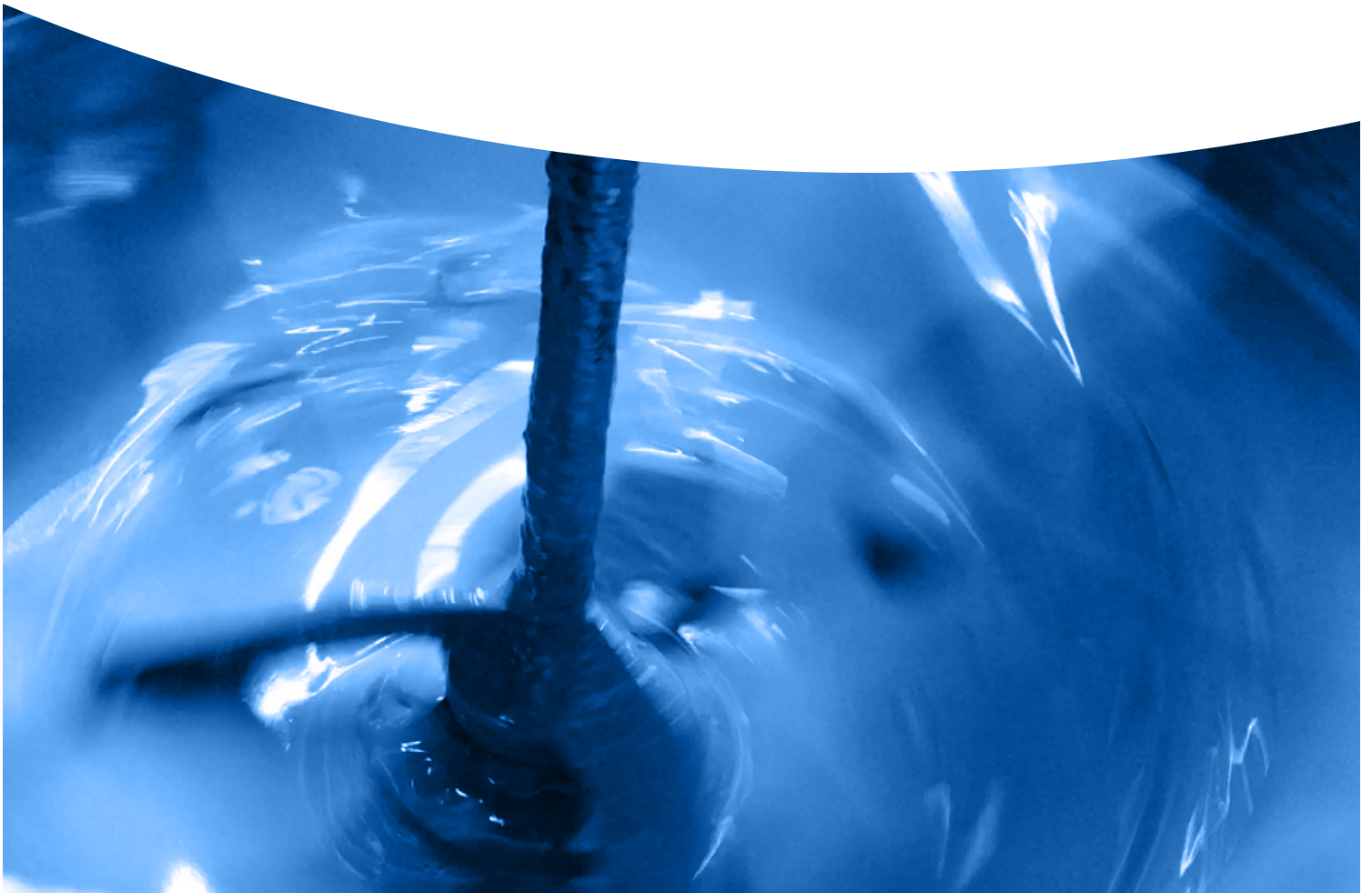

## Specialty Grout and Cement

### Bottom-Up 100 MPa Grout

Bottom-Up-100 is a pumpable cementitious grout for use as a bonding agent between a reinforcing member and the borehole wall in ground support systems. The product is packaged in durable water proof 20 kg bags for use in remote and harsh underground mining environments. The product is designed to minimise the risk of hard lumps entering pumping injection systems, which in turn minimises hazardous pressurisation and blockages.

#### Features:

- High strength 100 MPa cable bolt grout for “bottom-up” grouting
- Ready to use, mix with water and pump
- Excellent pumpability
- Non shrink, unique expansion system compensates for shrinkage
- Typically used with Bowen cables, 15.2mm triple/twin-strand cable bolts and trusses

#### Packaging:

- Durable water proof 20kg bags for use in remote and harsh underground mining environments
- 56 bags per pallet, 1.2 tonne per pallet



Uniaxial Compressive Strength* (MPa)			
	1 DAY	7 DAYS	28 DAYS**
5 litres/bag	60	100	105
6 litres/bag	55	90	100

\*UCS independent test results were obtained using 50 x 50mm cubes

\*\*28 day strength may vary between 85 MPa and 105 MPa depending on water content and testing methods utilised

Estimated yield 12-13 litres of grout at 5-6 litres of water per bag

Water : Grout Mix	5-6 litres per bag
Estimated Yield	12-13 litres per bag

## Specialty Grouts and Cements

### Top-Down 80 MPa Grout

Top-Down-80 is a pumpable cementitious grout for use as a bonding agent between a reinforcing member and the borehole wall in ground support systems. The product is packaged in durable water proof 20 kg bags for use in remote and harsh underground mining environments. The product is designed to minimise the risk of hard lumps entering pumping injection systems, which in turn minimises hazardous pressurisation and blockages.

#### Features:

- High strength 80 MPa thixotropic cable bolt grout for “top-down” grouting
- Ready to use, mix with water and pump
- Non shrink, unique expansion system compensates for shrinkage
- Excellent pumpability
- Typically used with TGBolt, Bulbed Superstrand and other “top-down” groutable cable bolts

#### Packaging:

- Durable water proof 20kg bags for use in remote and harsh underground mining environments
- 56 bags per pallet, 1.2 tonne per pallet

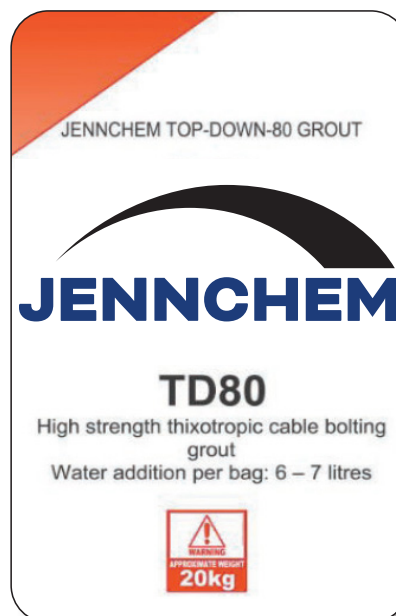

Uniaxial Compressive Strength* (MPa)			
	1 DAY	7 DAYS	28 DAYS**
6 litres/bag	43	77	89
7 litres/bag	33	63	80

\*UCS independent test results were obtained using 50 x 50mm cubes

\*\*28 day strength may vary between 70 MPa and 90 MPa depending on water content and testing method utilised

Estimated yield 13 - 14 litres of grout at 6 - 7 litres of water per bag

Water : Grout Mix	6-7 litres per bag
Estimated Yield	13-14 litres per bag

# Specialty Grouts and Cements

## J-PLUG GROUT

Jennchem's J-PLUG Grout is a pumpable cementitious grout designed for use in void filling applications and plugging of gas drainage holes.

**Features:**

- High volume output
- Non-shrink.
- Thixotropic
- Rapid setting
- Water addition-8.5L per 15Kg bag
- Once mixed the product is rapid setting
- Wash all equipment and pumping lines immediately after use

**Application:**

- Use a high shear mixer and potable water

**Yield:**

- One 15 Kg bag will typically yield 12.5 litres of grout

**Packaging:**

- 15Kg bags-72 bags per pallet

**Technical Data – J-PLUG GROUT**

Water:powder	Pump Life	Initial set time	Wet Density
0.56 :1	15-20 mins	30-40 mins	1850 Kg/m <sup>3</sup>

**Uniaxial Compressive Strength (MPa)**

1 day	7 days	28 days
3.5	10	20

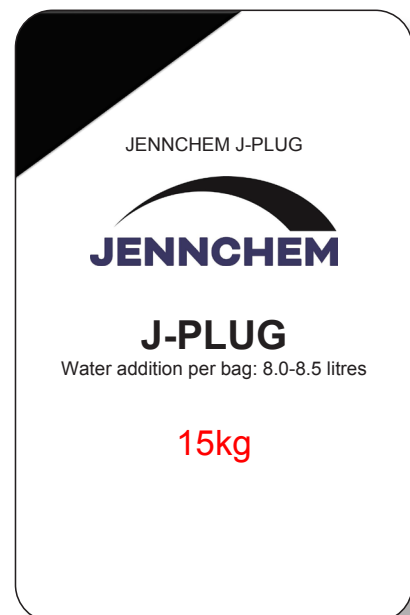

# Specialty Grouts and Cements

## J-URR GROUT (Jennchem Underground Roadway Repair)

Jennchem J-URR GROUT is a specially formulated fast-setting concrete designed for the mining and tunnelling industries. J-URR GROUT is designed specifically for demanding applications where quick return to service is required, or where traditional concrete mixing equipment is unavailable or impractical. J-URR GROUT is formulated to absorb water and gain strength rapidly with no mixing. J-URRGROUT is ideal for rehabilitating underground roadways and filling mud holes and swillies. J-URR GROUT is a safer, more permanent solution than temporary bridges or traditional fill methods.

### Features:

- Extremely Fast Setting
- Simple Application
- Quick return to service
- Safe to use
- Minimal dust make
- No mixing required
- Packaged in 1 tonne or 20kg bags
- Increases underground development production in wet conditions
- Fit for purpose QDS applicator available

### Packaging:

- 20kg bags. (56 per pallet)
- 1 tonne bulk bags

### Shelf Life:

- One year when stored in cool dry conditions

### Yield:

- 20kg: Approx. 15.4 litres
- 1000kg: Approx. 0.77m<sup>3</sup>

### Application

- Repaired area is only as durable as the underlying substrate.
- Remove mud or soft base if possible, put down rock or ballast and compact to provide solid base.
- Fill hole or depression with water (if not already filled) up to where the repair level is desired.
- Open packaging and dump material into standing water.
- Allow material to soak up water.
- Agitation with a shovel or other suitable tool can be used to improve mixing.
- Finish to desired texture. This can be done in multiple lifts if required.

### Set / Cure Time

Foot Traffic	Light Duty Traffic (Drifrunner)	Heavy Duty Traffic (Shuttle car, Jumbo)	Extreme Duty Traffic (Continuous miner)
10 minutes	30 minutes	4 hours	8 hours

Note: Hot materials (and/or water) will accelerate set times and strength gain. Cold materials will slow set times and strength gain. pH and chemistry of water may affect set time and strength gain.





# RESIN CAPSULES



# Resin Capsules

## '5 Star' Dual Speed (Water Based Catalyst) Resin Capsules

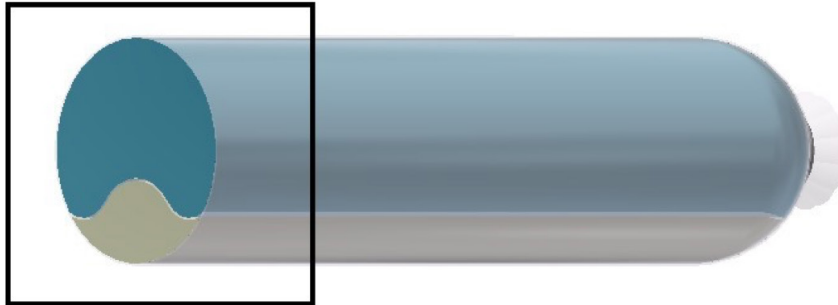

### Features:

- Water based catalyst as 20–30% of capsule volume compared to the traditional 5-10%
- Provides superior mixing
- Available in diameters of 25, (nominal), 26, 30, 36mm
- For full encapsulation of pre-tensioned rock bolts
- Cost effective

Punched shear strength (MPa)	>22 MPa		
Shelf life (months)	4		
Capsule length (mm)	800 – 1000	1100 – 1500	1600 – 1700
Quantity / box	25	20	15
Quantity / pallet	1050	840	720

Speed	Superfast/Slow	Extrafast/Slow	Fast/Slow	Medium/Slow
Hold time (s)	60	12-60	14-60	19-60

Refer to individual box label for spin and hold installation instructions

Available in standard or grit limestone filler configurations

Capsules  $\geq$  1000mm in length: To mix, apply rotation and feed the bolt up through the capsule at a rate of 1 sec per 100mm of capsule (eg 1200mm capsule = 12 sec). Continue mixing at the back of the hole for an additional 2-4 seconds then wait for the resin to set.

Capsules < 1000mm in length: To mix, apply rotation and feed the bolt up through the capsule at a rate of 1 sec per 100mm of capsule. Continue mixing until the total mix time = 10 sec then wait for the resin to set.

# Resin Capsules

## '5 Star' Single Speed (Water Based Catalyst) Resin Capsules

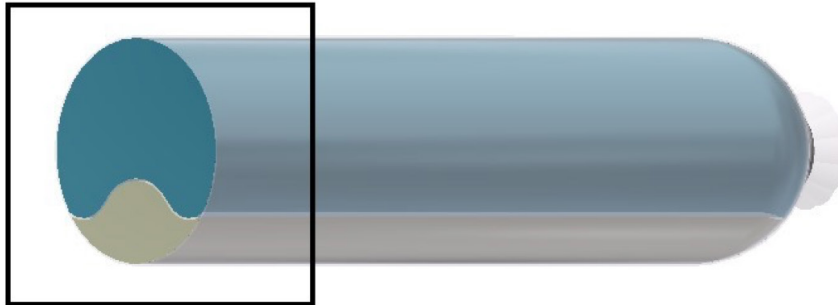

### Features:

- Water based catalyst as 20-30% of capsule volume compared to the traditional 5-10%
- Provides superior mixing
- Available in diameters of 25, (nominal), 26, 30, 36mm
- For anchoring of all types of rock bolts
- Cost effective

Punched shear strength (MPa)	>22 MPa		
Shelf life (months)	4		
Capsule length (mm)	800-1000	1100-1500	1600-1700
Quantity / box	25	20	15
Quantity / pallet	1050	840	720

Speed	Superfast	Extrafast	Fast	Medium	Slow
Hold time (s)	60	12-60	14-60	19-60	80

Refer to individual box label for spin and hold installation instructions

Available in standard or grit limestone filler configurations

Capsules  $\geq$  1000mm in length: To mix, apply rotation and feed the bolt up through the capsule at a rate of 1 sec per 100mm of capsule (eg 1200mm capsule = 12 sec). Continue mixing at the back of the hole for an additional 2-4 seconds then wait for the resin to set.

Capsules  $<$  1000mm in length: To mix, apply rotation and feed the bolt up through the capsule at a rate of 1 sec per 100mm of capsule. Continue mixing until the total mix time = 10 sec then wait for the resin to set.

# Resin Capsules

## Standard Dual Speed (Oil Based Catalyst) Resin Capsules

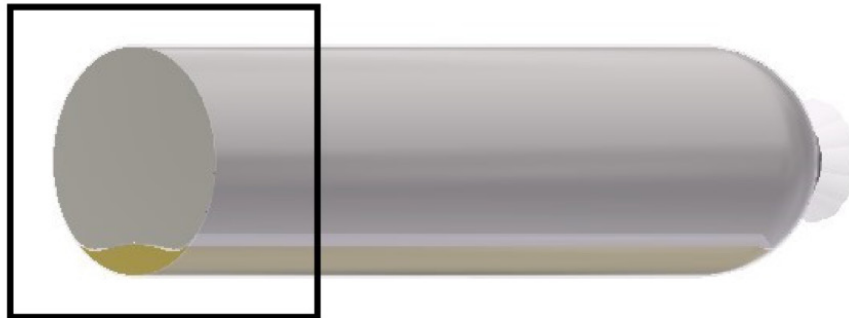

### Features:

- Separate resin mastic and catalyst encased within a thin plastic film, sealed at each end by wire clips
- Standard oil based catalyst as approximately 7% of capsule volume
- For full encapsulation of pre-tensioned rock bolts
- Available in diameters of 25, (nominal), 26, 30, 36mm
- Available in dual speed ratios 50:50, 40:60
- Other combinations available on request

Punched shear strength (MPa)	>22 MPa		
Shelf life (months)	4		
Capsule length (mm)	800-1000	1100-1500	1600-1700
Quantity / box	25	20	15
Quantity / pallet	1050	840	720

Speed	Superfast/Slow	Extrafast/Slow	Fast/Slow	Medium/Slow
Hold time (s)	10-60	12-60	14-60	19-60

Refer to individual box label for spin and hold installation instructions

Available in standard, grit and LIF limestone filler configurations

Capsules  $\geq$  1000mm in length: To mix, apply rotation and feed the bolt up through the capsule at a rate of 1 sec per 100mm of capsule (eg 1200mm capsule = 12 sec). Continue mixing at the back of the hole for an additional 2-4 seconds then wait for the resin to set.

Capsules  $<$  1000mm in length: To mix, apply rotation and feed the bolt up through the capsule at a rate of 1 sec per 100mm of capsule. Continue mixing until the total mix time = 10 sec then wait for the resin to set.

# Resin Capsules

## Standard Single Speed (Oil Based Catalyst) Resin Capsules

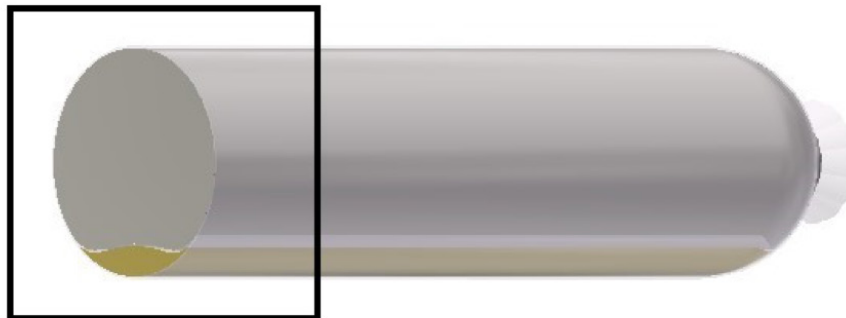

### Features:

- Separate resin mastic and catalyst encased within a thin plastic film, sealed at each end by wire clips
- Standard oil based catalyst as approximately 7% of capsules
- For general purpose anchoring of typical rebar rock bolts
- Available in diameters of 25, (nominal), 26, 30, 36mm
- Available gel times range from 10 seconds to 1.5 minutes

Punched shear strength (MPa)	>22 MPa		
Shelf life (months)	4		
Capsule length (mm)	800 - 1000	1100 - 1500	1600 - 1700
Quantity / box	25	20	15
Quantity / pallet	1050	840	720

Speed	Superfast	Extrafast	Fast	Medium	Slow
Hold time (s)	4	4	4	8	80

Refer to individual box label for spin and hold installation instructions

Available in standard, grit and LIF limestone filler configurations

Capsules  $\geq$  1000mm in length: To mix, apply rotation and feed the bolt up through the capsule at a rate of 1 sec per 100mm of capsule (eg 1200mm capsule = 12 sec). Continue mixing at the back of the hole for an additional 2-4 seconds then wait for the resin to set.

Capsules  $<$  1000mm in length: To mix, apply rotation and feed the bolt up through the capsule at a rate of 1 sec per 100mm of capsule. Continue mixing until the total mix time = 10 sec then wait for the resin to set.

# CANOPY TUBE SYSTEM



# PVC Canopy Tube System

## PVC Drainage and Ground Consolidation System

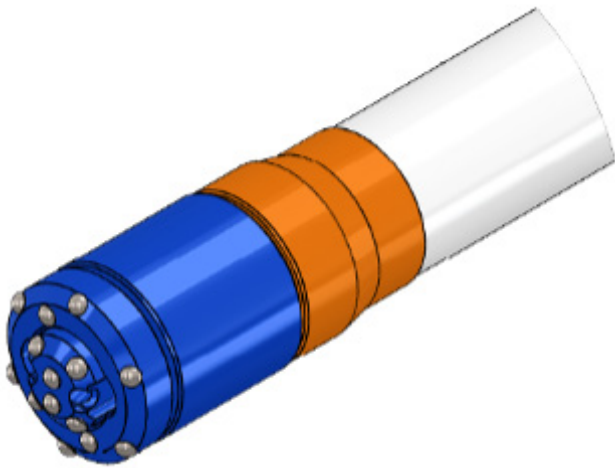

### Features:

- The Fiberglass SR Bolt rock bolt is a mechanical point anchored, pre tensioned, post groutable rock bolt with a grout injection head connection
- Situations in which water in the ground is or could be the primary cause of damage or destruction of building structures, devices must be used to re- establish the correct hydraulic drainage of the soil to prevent risks.
- KIMEX sub-horizontal drainage pipes, with a wide range of mechanical and hydraulic features, allow engineers to obtain the best performance of the terrain in every specific case. It is only through careful control and optimization of the presence of water in every type of terrain that it will be possible to ensure the maximum capacity and stability.

Kimex dewatering system with options for slotted pipes and grout valves in pvc for drainage and consolidation.

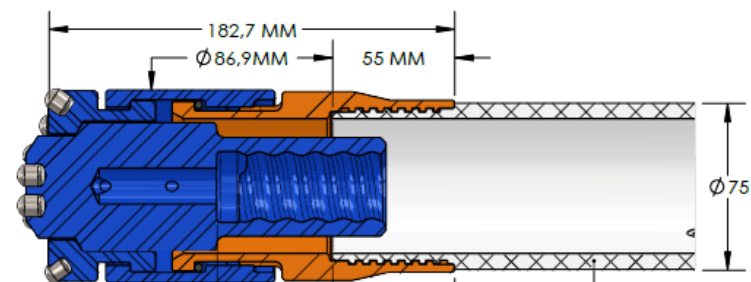

Dimensional Characteristics	
External Diameter (mm)	75
Internal Diameter (mm)	61.4
Wall Thickness (mm)	6.8
Thread Type	Male-Female Socket
Standard Length (m)	3

Property Physical - Mechanical Features
Specific Weight g/cm 1.4
Yield Point kg/cm <sup>2</sup> 338 ATSM method 638
Elongation at Break 8% ASTM method D 638
Tensile Strength kg/cm <sup>2</sup> 26000 Din 53457
Impact resistance at 20deg C No Break Din 53453 UNI 6323
Thermal Conductivity Kal/h m Deg C 13 Din 526/2
Hardness Shore D 80/82 ASTM D676

WWW.JENNMAR.COM.AU

**Head Office and Plant**

40-44 Anzac Avenue, Smeaton Grange NSW 2567

Ph: +61 2 4648 7500

Fax: +61 2 4648 7555

**Queensland Plant**

48-50 Southgate Drive, Paget QLD 4740

Ph: +61 7 4952 8700

Fax: +61 7 4952 8777

**Perth Plant**

84 Furniss Road, Lansdale WA 6065

Ph: +61 8 9408 9900

Fax: +61 8 9408 9999



**JENNMAR**

NOTE: Please confirm that you have the latest version of this catalogue by visiting [www.jennmar.com.au](http://www.jennmar.com.au) before using any of the technical specifications contained herein.

JC122024F